



**E I M A C**  
 Division of Varian  
 SAN CARLOS  
 CALIFORNIA

**3CW30,000H3**  
 MEDIUM-MU  
 WATER-COOLED  
 POWER TRIODE

The Eimac 3CW30,000H3 is a water-cooled, ceramic-metal power triode designed primarily for use in industrial radio-frequency heating services. Its water-cooled anode is conservatively rated at 30 kilowatts of plate dissipation with low water flow and pressure drop.

Input of 60 kilowatts is permissible up to 90 megahertz. Plentiful reserve emission is available from its one kilowatt filament. The grid structure is rated at 500 watts making this tube an excellent choice for severe applications.

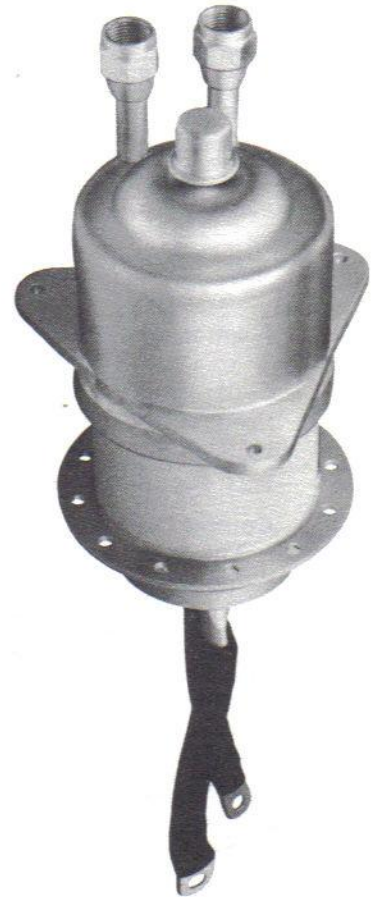

**GENERAL CHARACTERISTICS**

**ELECTRICAL**

	<i>Min.</i>	<i>Nom.</i>	<i>Max.</i>
Filament: Thoriated-Tungsten			
Voltage - - - - -		6.3	V
Current - - - - -	152		172 A
Amplification Factor - - - - -		20	
Interelectrode Capacitances, Grounded Cathode:			
Grid-Filament - - - - -	48		58 pF
Plate-Filament - - - - -	1.2		1.5 pF
Grid-Plate - - - - -	30		38 pF
Frequency for Maximum Ratings - - - - -			90 MHz

**MECHANICAL**

Base - - - - -	See Outline
Operating Position - - - - -	Vertical, base up or down
Cooling - - - - -	Water and Forced Air
Maximum Operating Temperatures:	
Ceramic-to-Metal Seals - - - - -	250°C
Maximum Dimensions:	
Height - - - - -	See Outline
Diameter - - - - -	See Outline
Net Weight - - - - -	12 pounds



**RF INDUSTRIAL OSCILLATOR**

Class-C (Filtered DC Power Supply)

**MAXIMUM RATINGS:**

DC PLATE VOLTAGE	- - - - -	12,000 VOLTS
DC PLATE CURRENT	- - - - -	6.0 AMPS
DC GRID VOLTAGE	- - - - -	—1000 VOLTS
DC GRID CURRENT	- - - - -	1.0 AMP
PLATE INPUT POWER	- - - - -	60 KW
PLATE DISSIPATION (NOMINAL)	- - - - -	30 KW

**TYPICAL OPERATION\***

DC Plate Voltage	- - - - -	7000	10,000 volts
DC Plate Current	- - - - -	6.0	6.0 amps
DC Grid Voltage	- - - - -	—600	—800 volts
DC Grid Current	- - - - -	.66	.315 amps
Peak Positive Grid Voltage	- - - - -	440	360 volts
Driving Power	- - - - -	660	365 watts
Plate Input Power	- - - - -	42	60 kW
Plate Dissipation	- - - - -	12	18 kW
Plate Output Power	- - - - -	30	42 kW
Approximate Load Impedance	- - - - -	600	750 ohms

\*Loaded Conditions

Note: "TYPICAL OPERATION" data are obtained by calculation from published characteristic curves. No allowance for circuit losses has been made.

**APPLICATION****ELECTRICAL****Filament**

The rated filament voltage for the 3CW30,000H3 is 6.3 volts. Filament voltage, as measured at the tube, must be maintained at 6.3 volts plus or minus five percent for maximum tube life and consistent performance.

**Control Grid Operation**

The grid current rating is one ampere dc. This value should not be exceeded for more than very short periods such as during tuning and over-current protection in the grid circuit should be provided. Ordinarily it will not be necessary to operate with more than 0.4 to 0.6 amperes grid current to obtain reasonable efficiency. In industrial heating service with varying loads, grid current should be monitored continuously with a dc current meter. The maximum grid dissipation rating is 500 watts.

**Plate Operation**

Maximum plate voltage rating of 12,000 volts and maximum plate current of 6.0 amperes dc should not be applied simultaneously as rated plate dissipation may be exceeded. The 60 kilowatts input rating applies for Class C amplifier or oscillator service with no modulation.

Plate over-current protection should be provided to remove plate voltage quickly in the event of an overload or an arc-over at the load. In addition current limiting power supply resistors should be used. These precautions are especially important in industrial service with its wide variations in loading.

Spark gaps from plate to ground should be used to prevent transient voltages from flashing across the tube envelope during any fault conditions.

**High Frequency Operation**

The 3CW30,000H3 is usable to 140 MHz. At this frequency, plate voltage must be reduced to 7000 volts in Class C service.

**MECHANICAL****Mounting**

The 3CW30,000H3 must be mounted vertically, either base up or down.

**Cooling**

Anode cooling is accomplished by circulating water through the integral anode-water jacket.

The table below lists the minimum water flow requirement for adequate anode cooling at various plate dissipation levels. In all cases, the outlet water temperature must not exceed 70°C nor should inlet water pressure exceed 60 psi. This table is based upon 20°C temperature rise.

MINIMUM WATER-COOLING REQUIREMENT

Plate Dissipation (kW)	Water Flow (gpm)	Pressure Drop (psi)
20	4	3.5
25	5	4.0
30	6	4.5
35	7	5.0

Additional forced-air cooling of the tube's base is also required to maintain ceramic-to-metal seal temperatures below the 250°C maximum. Approximately 50 cfm of cooling air directed into the base structure will generally satisfy this requirement.

**Special Application**

If it is desired to operate this tube under conditions widely different from those given here, write to Power Grid Tube Div., EIMAC, Division of Varian, 301 Industrial Way, San Carlos, Calif. for information and recommendations.

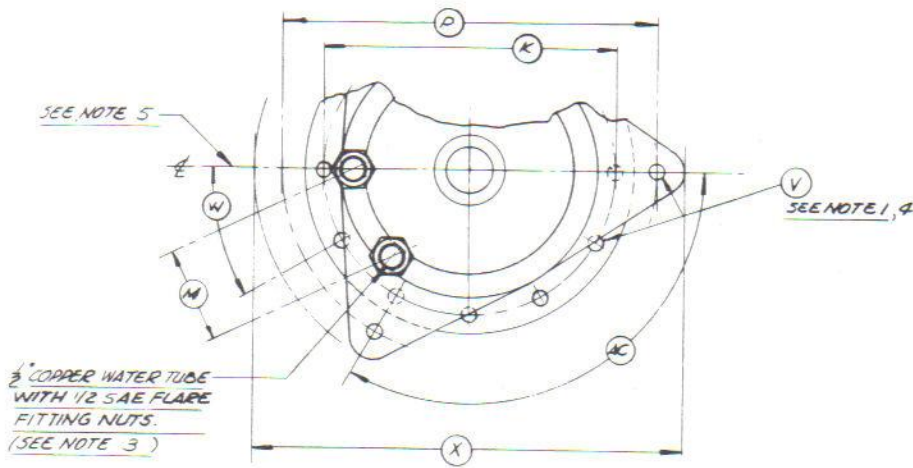

3/8" COPPER WATER TUBE WITH 1/2 SAE FLARE FITTING NUTS. (SEE NOTE 3)

DIMENSIONS IN INCHES			
DIMENSIONAL DATA			
DIM.	MIN.	MAX.	REF.
A	4.050	4.250	
B	.860	.890	
C	.720	.760	
F	3.792	3.832	
H	.530	.700	
J			.125
K	4.425	4.445	
L	5.030	5.090	
M			1.500
N	.375		
P	5.990	6.010	
R	.800	.860	
S	3.300	3.500	
T	3.950	4.100	
U	8.250	8.750	
V			.250
W	29°	31°	
X			6.750
Y			.250
Z			2.000
AA	8.500	9.000	
AB			2.000
AC	118°	122°	
AD			.390

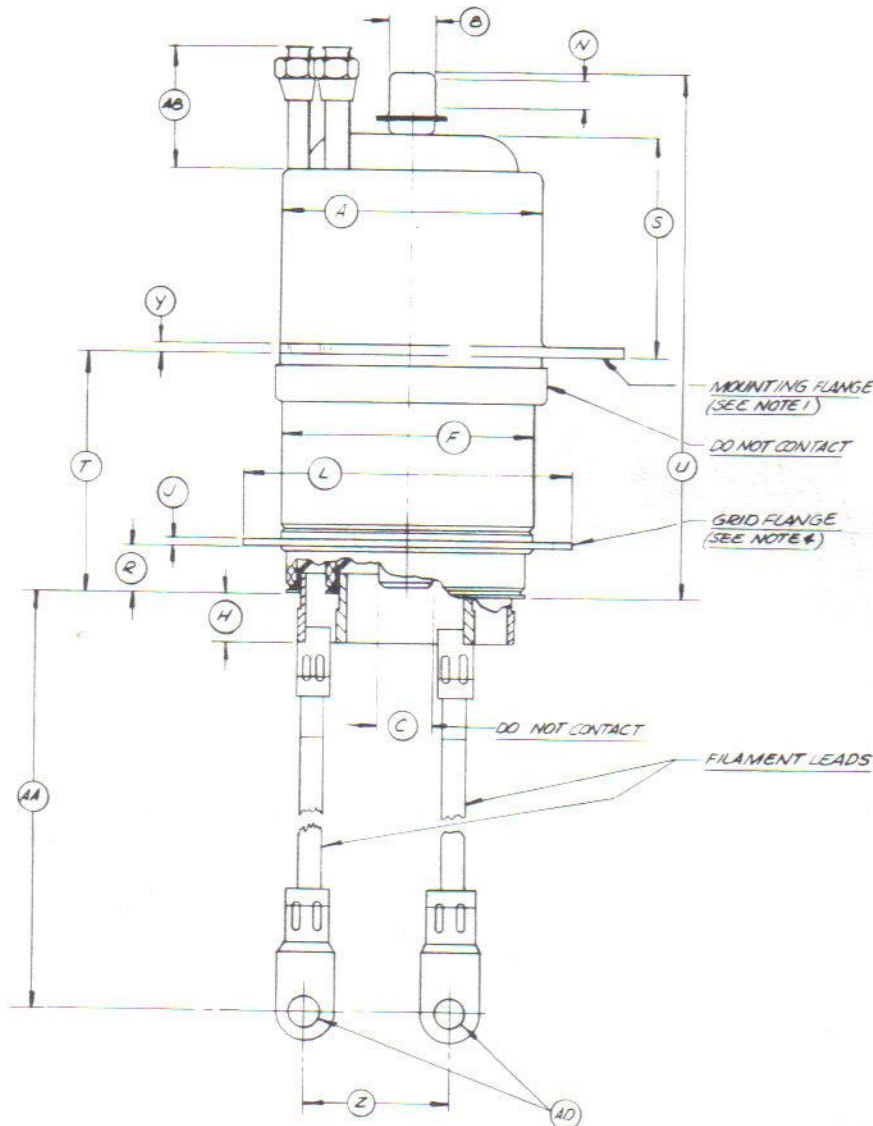

NOTES:

1. 3 MOUNTING HOLES IN MTG. FLANGE.
2. REF. DIMS. ARE FOR INFO. ONLY AND ARE NOT REQ'D FOR INSP. PURPOSES.
3. EITHER FITTING CAN BE USED AS INLET OR OUTLET.
4. 12 HOLES IN GRID FLANGE.
5. MTG. FLANGE, FIL. LEADS & WATER FITTINGS ARE TO BE ORIENTED AS SHOWN.





3CW30,000H3

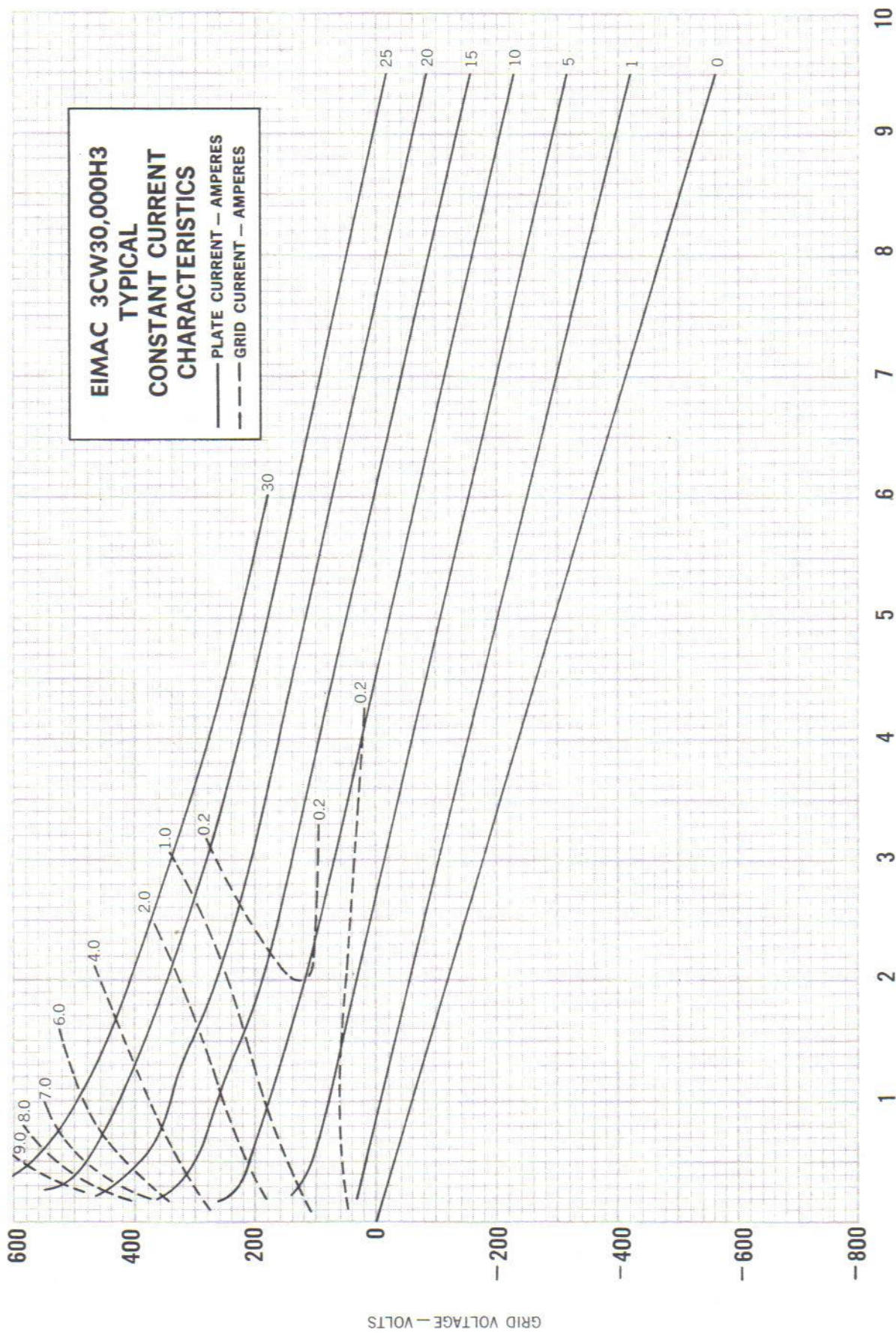

PLATE VOLTAGE — KILOVOLTS