



E I M A C
 Division of Varian
 SAN CARLOS
 CALIFORNIA

SK-1306
SK-1406
 AIR-SYSTEM
 CHIMNEYS

The SK-1306 and SK-1406 Air-System Chimneys are intended for use with the tube and socket combinations listed below. They are used to direct cooling air to the tube's anode cooling fins after it has been forced through the companion Air-System Socket.

MATERIALS

These chimneys are molded from a grey, thermosetting polyester premix compound per MIL-R-7675.

INSTALLATION

The SK-1306 and SK-1406 Air-System Chimneys are mounted above the chassis or pressurized compartment, directly over the companion socket. The chimneys are secured by the eight equally spaced machine screws on a $7\frac{3}{4}$ " P.C. that are used to install the socket.

CHIMNEY/TUBE/SOCKET COMBINATIONS

CHIMNEY	TUBE	SOCKET
SK-1306	3CX10,000A1 3CX10,000A3 3CX10,000A7	SK-1300
	4CX10,000D	SK-300 SK300A
SK-1406	4CX3000A	SK-1400A SK-1470A



SK-1306 Chimney shown with 4CX10,000 and SK-300 socket

Net Weight - - - - -

SK-1306 — 8 ounces
 SK-1406 — 7 ounces



DIMENSIONS IN INCHES

REF.	MIN.	MAX.	NOTE
A	7.062	7.094	
B	7.734	7.766	
C	8.230	8.265	
C	3.609	3.656	
E	.093	.125	
F	44°	46°	
H	.140	.172	
J	.062	.109	

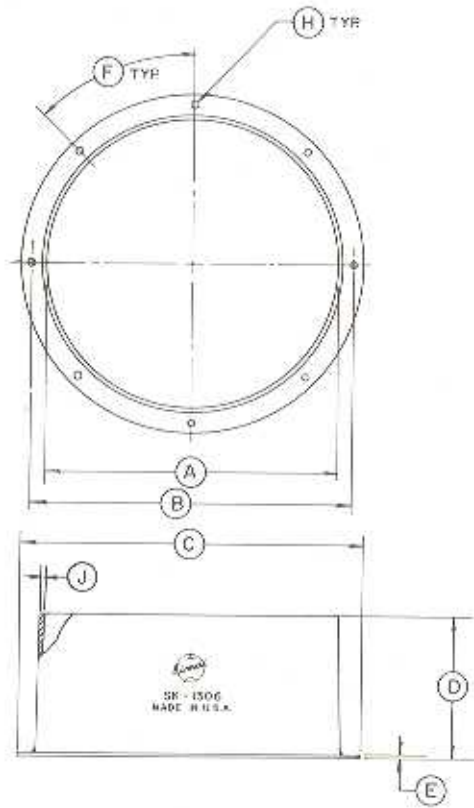

SK-1306

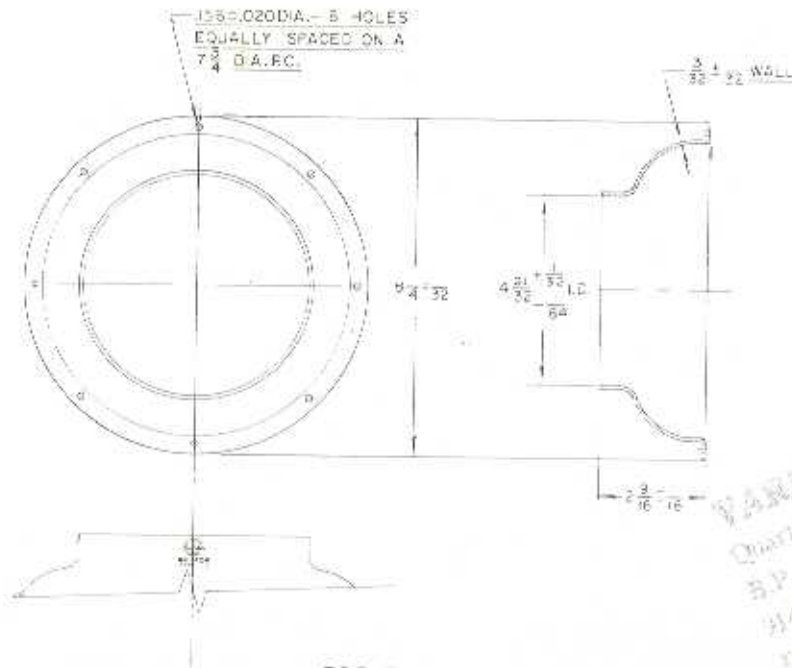

SK-1406

VARIAN S.A.
 Quarter de Colombes
 B.P. n° 12
 91400 ORSAY
 Tel. 907.78.20