



**Compaq R6000 Series UPS
Operation and Reference Guide**

Second Edition (March 1999)
Part Number 347223-022
Compaq Computer Corporation

Notice

The information in this publication is subject to change without notice.

COMPAQ COMPUTER CORPORATION SHALL NOT BE LIABLE FOR TECHNICAL OR EDITORIAL ERRORS OR OMISSIONS CONTAINED HEREIN, NOR FOR INCIDENTAL OR CONSEQUENTIAL DAMAGES RESULTING FROM THE FURNISHING, PERFORMANCE, OR USE OF THIS MATERIAL. THIS INFORMATION IS PROVIDED "AS IS" AND COMPAQ COMPUTER CORPORATION DISCLAIMS ANY WARRANTIES, EXPRESS, IMPLIED OR STATUTORY AND EXPRESSLY DISCLAIMS THE IMPLIED WARRANTIES OF MERCHANTABILITY, FITNESS FOR PARTICULAR PURPOSE, GOOD TITLE AND AGAINST INFRINGEMENT.

This publication contains information protected by copyright. No part of this publication may be photocopied or reproduced in any form without prior written consent from Compaq Computer Corporation.

© 1999 Compaq Computer Corporation.

All rights reserved. Printed in the U.S.A.

The software described in this guide is furnished under a license agreement or nondisclosure agreement. The software may be used or copied only in accordance with the terms of the agreement.

Compaq, Deskpro, Fastart, Compaq Insight Manager, Systempro, Systempro/LT, ProLiant, ROMPaq, QVision, SmartStart, NetFlex, QuickFind, PaqFax, ProSignia, registered United States Patent and Trademark Office.

Neoserver, Netelligent, Systempro/XL, SoftPaq, QuickBlank, QuickLock are trademarks and/or service marks of Compaq Computer Corporation.

Microsoft, MS-DOS, Windows, and Windows NT are registered trademarks of Microsoft Corporation.

Pentium is a registered trademark and Xeon is a trademark of Intel Corporation.

Other product names mentioned herein may be trademarks and/or registered trademarks of their respective companies.

Compaq R6000 Series UPS Operation and Reference Guide
Second Edition (March 1999)
Part Number 347223-022

Contents

About This Guide

Text Conventions	vii
Symbols in Text.....	vii
Symbols on Equipment.....	viii
Rack Stability	ix
Getting Help	ix
Compaq Technical Support	ix
Compaq Website	x
Compaq Authorized Reseller	x

Chapter 1

Introduction

Compaq R6000 UPS Series Models	1-1
Front Panel	1-2
Rear Panel.....	1-3
Compaq R6000 UPS Features	1-4
Communication Ports	1-4
Front Panel LEDs	1-5
Front Panel Controls and LCD Display.....	1-6
Power Management Software	1-7
Compaq Power Management Software	1-7
Hardware Options	1-8
Extended Runtime Modules (ERMs)	1-13
Remote Emergency Power Off (REPO) Port	1-14
Warranty	1-14
\$25,000 Computer Load Protection Guarantee	1-14
Pre-Failure Battery Warranty	1-15

Chapter 2

Installation

Important Safety Instructions	2-1
About This Device.....	2-1

Installation

continued

Installation Considerations	2-2
Weight	2-2
Position	2-2
Outline of Installation Procedure	2-3
Check Battery Recharge Label	2-4
Unpacking the UPS	2-4
Preparing the Rack	2-4
Assembling the Compaq R6000 UPS	2-5
Placing UPS in rack	2-5
Wiring the Compaq R6000 UPS	2-7
Code Compliance Information	2-7
Connecting the Remote Emergency Power Off Switch (REPO) Port	2-7
Connecting the Compaq R6000 UPS to AC Branch Circuit	2-9
Install and connect the battery packs	2-12
Installing Extended Runtime Modules (ERMs)	2-16
Connecting Communications Ports	2-17
Connecting Communication Ports to Other Devices	2-17
Installing and Connecting Communication Options	2-18
Connecting Loads	2-18
Load Segments Description	2-18
Configuring Load Segments	2-19
Attaching the Load Segments	2-19
Ordering Extra Power Cords	2-19
Completing the Assembly of the R6000 UPS in the Rack	2-20
Powering up the R6000 UPS	2-21
Turning on the Main Circuit Breaker	2-21
Pressing the ON button	2-21
Shutting Down the System	2-21
Charging Batteries	2-22
Installation is Now Complete	2-22

Chapter 3

Operation

Front Panel Controls	3-2
Front Panel Indicators	3-3
Front Panel LCD	3-3
Front Panel LEDs	3-4
Modes of Operation	3-5
Shutting Down the System	3-6
Initiating a Self-test	3-7
Audible Alarm	3-7
Silencing an Audible Alarm	3-8

Chapter 4

Configuration

Changing Configuration Parameters	4-1
Matching the Utility Voltage	4-2
Configuring the COMPAQ R6000 UPS Using the LCD Display Menu	4-3
LCD Display Menu Structure	4-4
Initial Power-Up Display	4-4
Top Level Main Menu	4-4
Sub-Menu Choices	4-4
Status	4-5
Meters	4-7
Active Alarms	4-9
Battery Data	4-11
Firmware Version	4-12
Load Control	4-13
Display Test	4-13
System Setup	4-14

Chapter 5

Battery Maintenance

Precautions	5-2
Charging Batteries	5-2
When to Replace Batteries	5-3
Pre-Failure Battery Warranty	5-3
Obtaining New Batteries	5-3
How to Replace Batteries	5-4
Before Replacing Batteries	5-4
Removing the Battery Packs	5-4
Installing New Batteries	5-8
Disposing of Used Batteries	5-10
Care and Storage of Batteries	5-10
Extended Runtime Module (ERM) Batteries	5-10

Chapter 6

Troubleshooting

Responding to Audible Alarms	6-2
<i>Acknowledgement</i> Audible Alarm	6-2
<i>Shutdown Imminent</i> Audible Alarm	6-2
<i>Shutdown within 30 seconds</i> Audible Alarm	6-3
<i>Loads in Jeopardy</i> Audible Alarm	6-4
<i>Warning</i> Audible Alarm	6-5
<i>Caution</i> Audible Alarm	6-6
COMPAQ R6000 UPS Trouble Indicators	6-8
LED Alarm Configurations	6-9
Repairing the UPS	6-10

Appendix A

Regulatory Compliance Notices

Federal Communications Commission Notice	A-1
Class A Equipment	A-2
Class B Equipment	A-2
Declaration of Conformity for Products Marked with FCC Logo, United States Only.....	A-2
Modifications.....	A-3
Cables	A-3
Canadian Notice (Avis Canadien)	A-3
Class A Equipment	A-3
Class B Equipment	A-3
European Union Notice	A-4
Japanese Notice	A-4
Class A/B Equipment	A-4
Taiwanese Notice.....	A-4
Battery Replacement Notice	A-5

Appendix B

Electrostatic Discharge

Grounding Methods	B-2
-------------------------	-----

Appendix C

Specifications

Physical Specifications	C-2
Input Specifications	C-2
Output Specifications.....	C-3
Battery Specifications	C-5
Environmental Specifications	C-5

Index

About This Guide

This guide is designed to be used as step-by-step instructions for installation and as a reference for operation, troubleshooting, and future upgrades.

Text Conventions

This document uses the following conventions to distinguish elements of text:

Keys	Keys appear in boldface. A plus sign (+) between two keys indicates that they should be pressed simultaneously.
USER INPUT	User input appears in a different typeface and in uppercase.
<i>FILENAMES</i>	File names appear in uppercase italics.
Menu Options, Command Names, Dialog Box Names	These elements appear in initial capital letters.
COMMANDS, DIRECTORY NAMES, and DRIVE NAMES	These elements appear in uppercase.
Type	When you are instructed to <i>type</i> information, type the information without pressing the Enter key.
Enter	When you are instructed to <i>enter</i> information, type the information and then press the Enter key.

Symbols in Text

These symbols may be found in the text of this guide. They have the following meanings.



WARNING: Text set off in this manner indicates that failure to follow directions in the warning could result in bodily harm or loss of life.



CAUTION: Text set off in this manner indicates that failure to follow directions could result in damage to equipment or loss of information.

IMPORTANT: Text set off in this manner presents clarifying information or specific instructions.

NOTE: Text set off in this manner presents commentary, sidelights, or interesting points of information.

Symbols on Equipment

These icons may be located on equipment in areas where hazardous conditions may exist.



Any surface or area of the equipment marked with these symbols indicates the presence of electrical shock hazards. Enclosed area contains no operator serviceable parts.

WARNING: To reduce the risk of injury from electrical shock hazards, do not open this enclosure.



Any RJ-45 receptacle marked with these symbols indicates a Network Interface Connection.

WARNING: To reduce the risk of electrical shock, fire, or damage to the equipment, do not plug telephone or telecommunications connectors into this receptacle.



Any surface or area of the equipment marked with these symbols indicates the presence of a hot surface or hot component. If this surface is contacted, the potential for injury exists.

WARNING: To reduce the risk of injury from a hot component, allow the surface to cool before touching.



Any product or assembly marked with these symbols indicates that the component exceeds the recommended weight for one individual to handle safely. **WARNING:** To reduce the risk of personal injury or damage to the equipment, observe local occupational health and safety requirements and guidelines for manual material handling.

68-136 kg

150-300 lb

Rack Stability



WARNING: To reduce the risk of personal injury or damage to the equipment, be sure that:

- a. The leveling jacks are extended to the floor.
 - b. The full weight of the rack rests on the leveling jacks.
 - c. The stabilizing feet are attached to the rack if it is a single rack installation.
 - d. The racks are coupled together in multiple rack installations.
 - e. A rack may become unusable if more than one component is extended for any reason. Extend only one component at a time.
-

Getting Help

If you have a problem and have exhausted the information in this guide, you can get further information and other help in the following locations.

Compaq Technical Support

You are entitled to free hardware technical telephone support for your product for as long you own the product. A technical support specialist will help you diagnose the problem or guide you to the next step in the warranty process.

In North America, call the Compaq Technical Phone Support Center at 1-800-OK-COMPAQ¹. This service is available 24 hours a day, 7 days a week.

Outside North America, call the nearest Compaq Technical Support Phone Center. Telephone numbers for world wide Technical Support Centers are listed on the Compaq website. Access the Compaq website by logging on to the Internet at <http://www.compaq.com>.

Be sure to have the following information available before you call Compaq:

- Technical support registration number (if applicable)
- Product serial number (s)
- Product model name(s) and numbers(s)
- Applicable error messages
- Add-on boards or hardware
- Third-party hardware or software

¹ For continuous quality improvement, calls may be recorded or monitored.

- Operating system type and revision level
- Detailed, specific questions

Compaq Website

The Compaq website has information on this product as well as the latest drivers and Flash ROM images. You can access the Compaq website by logging on to the Internet at <http://www.compaq.com>.

Compaq Authorized Reseller

For the name of your nearest Compaq Authorized Reseller:

- In the United States, call 1-800-345-1518.
- In Canada, call 1-800-263-5868.
- Elsewhere, see the Compaq website for locations and telephone numbers.

Chapter 1

Introduction

This chapter contains information on the following topics:

- The Compaq R6000 Uninterruptible Power Supply (UPS) series models
- Compaq R6000 UPS front panel
- Compaq R6000 UPS rear panel
- Compaq R6000 UPS features
- The \$25,000 Computer Load Protection Guarantee
- Pre-Failure Battery Warranty

Compaq R6000 UPS Series Models

The Compaq R6000 UPS Series includes the following models:

Table 1-1
Compaq R6000 UPS Series Models

UPS Model	Part Number	Comments
R6000	347207-001	North American; high voltage. Rack mount.
R6000j	347207-291	Japanese; high voltage. Rack mount.
R6000i	347207-B31	International; high voltage. Rack mount.

Front Panel

The Compaq R6000 Series UPS is a rack-mount model.

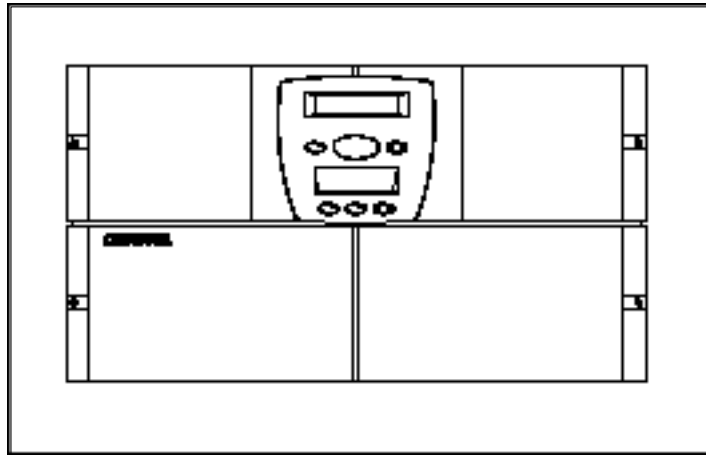

Figure 1-1. The R6000 front panel

Rear Panel

The Compaq R6000 UPS Series features the following rear panel configuration:

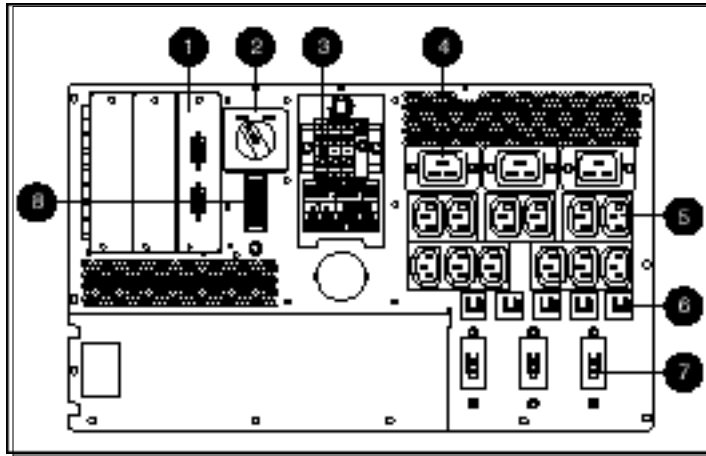

Figure 1-2. The R6000 rear panel

- ① Compaq R6000 UPS communication ports
- ② Manual Bypass switch
- ③ Input terminal block
- ④ 16 Amp receptacle
- ⑤ 10 Amp receptacle
- ⑥ Circuit breakers for segments (left to right) 1, 2, 3, 4, and 5
- ⑦ Circuit breakers for (left to right)
 - Segments 1 and 4
 - Segments 2
 - Segments 3 and 5
- ⑧ REPO port

Compaq R6000 UPS Features

Numerous features make the Compaq R6000 UPS both versatile and user-friendly:

- Two serial communication ports
- Five independent load segments (including three 16 Amp IEC-320, and twelve 10 Amp IEC-320 receptacles)
- Front panel controls and LCD display for easy configuration, monitoring, and operation
- Expanded support for Compaq Power Management Software
- Support for Compaq Extended Runtime Modules, options that extend the available runtime of the UPS
- Support for Compaq hardware option cards that further extend the power management capabilities of the UPS
 - Compaq Multi-Server UPS Card
 - Compaq Scalable UPS Card
 - Compaq SNMP-EN Adapter
- Support for Remote Emergency Power Off (REPO)

Communication Ports

The Compaq R6000 UPS includes two communications ports (Port 1 and Port 2) that allow data-exchange with host computers.

The Compaq R6000 UPS uses special DE9 cables for communication with host computers.



CAUTION: Use only the DE9 cables supplied by Compaq to connect the communications port to the host computer. Use of standard RS-232 cables may cause equipment damage.

Front Panel LEDs

The front panel has four LEDs to indicate the UPS operating mode.

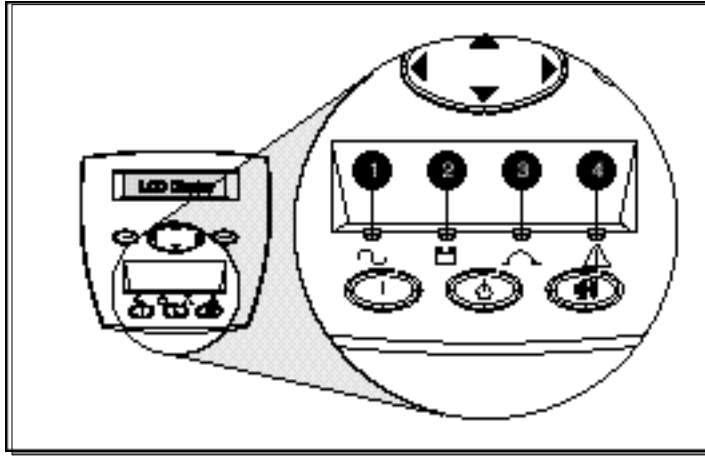

Figure 1-3. The front panel

LED	LED Color	LED Meaning
①	Green	Solid green means normal operation. Flashing green means Standby.
②	Yellow	Solid yellow means the UPS is on Battery; flashing yellow means UPS is on Battery and Standby
③	Yellow	Solid yellow means the UPS is on Bypass.
④	Red	Solid red means current or impending problems.

Front Panel Controls and LCD Display

The front panel controls and LCD display provide an easy-to-use UPS interface for setup, load control, and status monitoring. The front panel features six button controls.

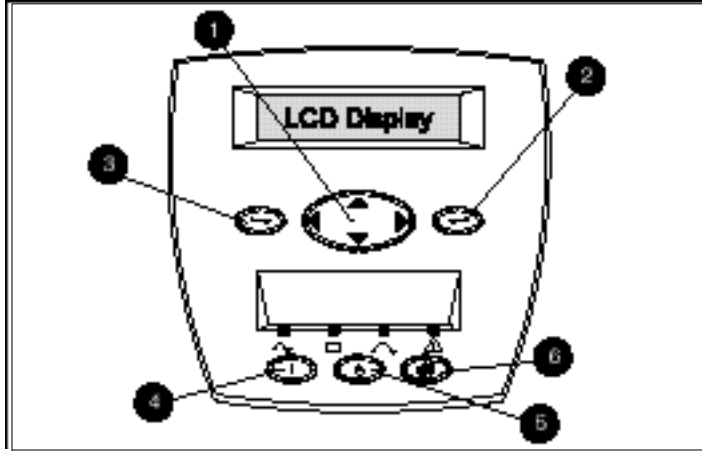

Figure 1-4. The Front Panel Controls

Control	Name	Function
①	Center	Large 4-way rocking button; used to control navigation through LCD menu structure: UP, DOWN, LEFT and RIGHT.
②	Enter	Used to navigate and select options in the LCD menu structure
③	Escape	Used to navigate and deselect options in the LCD menu structure
④	ON	Used to control status
⑤	STANDBY	Used to control status
⑥	TEST/RESET ALARM	Used to control functions

Power Management Software

Compaq supplies three power management software packages with each UPS:

- Compaq Power Management Software is a comprehensive Microsoft Windows-based management application that is tightly integrated with Compaq Insight Manager.
- Compaq LanSafe III provides UPS power management capabilities in a network environment.
- Compaq FailSafe III provides UPS power management capabilities in a localized computer environment.

NOTE: Outside of the Compaq Power Management Software, Compaq OnliNet provides support for the Compaq SNMP-EN Adapter.

Compaq Power Management Software

Compaq Power Management Software enables system administrators using Compaq Insight Manager to monitor and manage the power being supplied to an entire network of servers and workstations.

The software capabilities include:

- Monitoring utility power and the power supplied by the UPS
- Logging events, such as utility power blackouts and brownouts
- Prioritizing protected devices
- Start-up and shutdown of protected devices
- Controlling extended capabilities, through the use of Compaq Multi-Server UPS Cards, Compaq Scalable UPS Cards, and the Compaq SNMP-EN Adapter.

For example, if Compaq Power Management Software detects a protracted utility power blackout projected to exceed battery-supplied power limits, the application initiates a shutdown sequence specified by the system administrator. This sequence might include:

- Saving work-in-progress throughout the network
- Powering off non-critical devices to extend available battery power
- Completing an orderly device shutdown after saving critical data

For more information on using Compaq Power Management Software, refer to the “Compaq Power Products Software Reference Guide,” available on the Power Products Information Library CD.

Hardware Options

Six options are available for the Compaq R6000 UPS.

Table 1-2
Hardware Options

Option	Part Number
Compaq Extended Runtime Module	347224-B21
Compaq SNMP-EN Adapter	347225-B21
Compaq Multi-Server UPS Card	123508-B21
Compaq Scalable UPS Card	123509-B21
Compaq PDU High Voltage Models	NA Only—295363-002 INTL—295363-B31
Compaq High to Low Voltage Transformer (250VA)	388643-B21

UPS Option Cards

Two option slots are available to further expand the capabilities of the Compaq R6000 UPS in both power control and server communication for networking environments.

Option kits include the Compaq Multi-Server UPS Card, the Compaq Scalable UPS Card and the Compaq SNMP-EN Adapter. These enhancements provide communication with multiple systems, multiple UPS units, and network management applications.

Option kits can be used in the following configurations:

**Table 1-3
Option Card Matrix**

Case	Slot	Multi-Server	Scalable	SNMP-EN Adapter	Direct Connect Result (no PDU)
1	1	X			3 servers managing a total of 5 load segments
	2				
2	1	X			5 servers managing a total of 5 load segments
	2	X			
3	1		X		1 server managing a total of 9 load segments
	2				
4	1		X		1 in-band connection managing a total of 9 load segments
	2			X	
5	1			X	1 in-band connection managing a total of 5 load segments
	2				

Notes: Board combinations can be used in the primary UPS only. When UPS units are chained, no additional boards can be used in the other units.

For installation instructions, please see the Compaq Hardware Option Installation Guides that come with the option card kits.

Compaq Multi-Server UPS Card

Without a Compaq Multi-Server UPS Card, the UPS can communicate with two host computers. The Compaq Multi-Server UPS Card enables one UPS to communicate with up to four host computers by using all three ports on the option card and the open port on the UPS. (Port 1 will connect the card to the UPS through the pigtail cable on the card.)

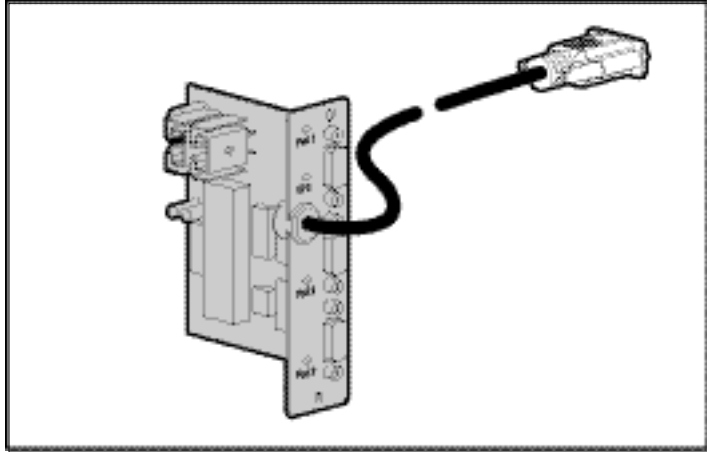

Figure 1-5. The Multi-Server UPS Card

Compaq Power Management software enables a single UPS with one Compaq Multi-Server UPS Card to protect up to four servers. If two Compaq Multi-Server UPS Cards are installed, five servers can be separately protected by plugging the servers into different Compaq R6000 UPS load segments.

Even if a network includes five servers running three different operating systems—three running Windows NT, one running UNIX, and one running NetWare—two Compaq Multi-Server Cards will directly communicate between the UPS and all five servers. Each server and its associated devices can be powered from a different UPS load segment.

Compaq Scalable UPS Card

The Compaq Scalable UPS card enables up to three UPS units to appear as a single virtual UPS to the host computer. Compaq Power Management Software gives users the capability to scale up the level of power protection available to the system.

For example, connecting three Compaq R6000 UPS units to one Scalable UPS card creates a virtual 18 kVA UPS. The virtual UPS would have nine independently-controlled load segments.

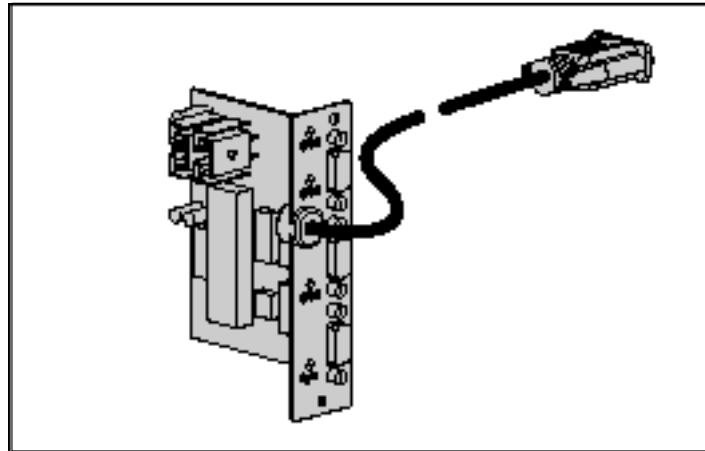

Figure 1-6. The Scalable UPS Card

Compaq SNMP-EN Adapter

The Compaq SNMP-EtherNet Adapter is a user interface to the UPS in a network where SNMP-based network management software is installed (Compaq OnliNet). Using the SNMP-EN Adapter's communication interface, system administrators can virtually eliminate costly downtime due to power outages and/or surges. This will decrease day-to-day network management annoyances like spontaneous rebooting, lost files and corrupted data—issues resulting from inconsistent power. The Compaq SNMP-EN Adapter provides the means to quickly ascertain if a power-related problem exists anywhere on the network.

The Compaq SNMP-EN Adapter lets you monitor the network without having to run power management software on a server. Other network components—like hubs and routers—can be monitored, even when Compaq Power Management Software is not in use.

The Compaq SNMP-EN Adapter Kit includes Compaq OnliNet software and documentation, as well as information on installing and configuring the Compaq SNMP-EN Adapter using MIB and Power MIB.

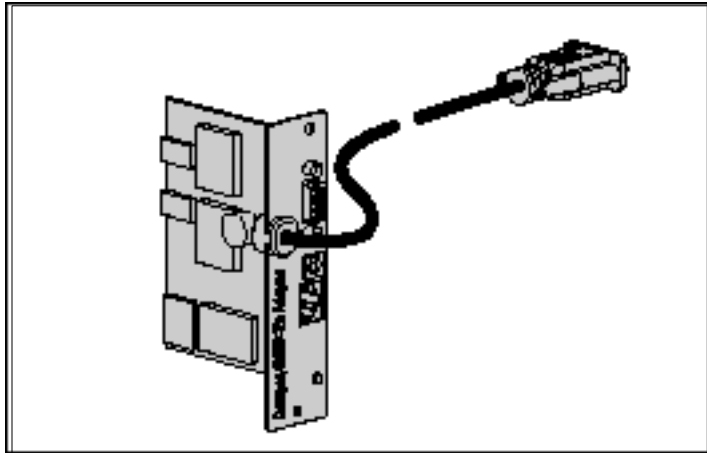

Figure 1-7. The SNMP-EN Adapter

Extended Runtime Modules (ERMs)

The Compaq R6000 UPS also supports Extended Runtime Modules. The UPS rear panel includes a power receptacle where the modules attach. Each ERM consists of dual battery packs in a 3U chassis.

At the recommended 80% load, one ERM will extend the available UPS runtime up to 18 minutes. Two ERMs can be serially connected to each UPS, increasing the total available runtime to up to 30 minutes.

NOTE: These figures were derived using the Compaq recommended 80% load.

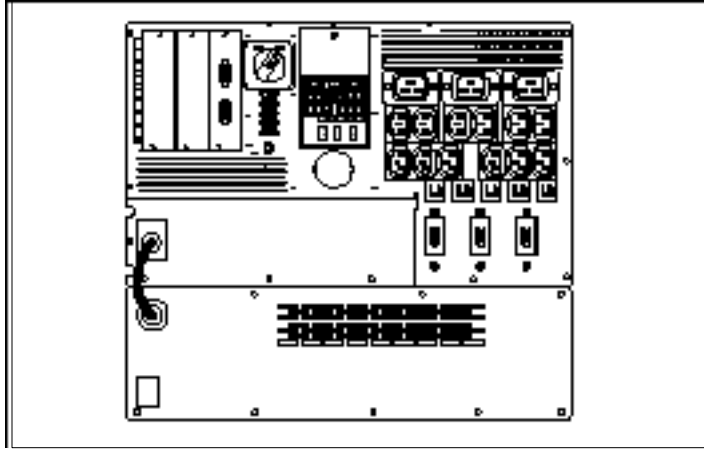

Figure 1-8. Back panel with installed Extended Runtime Module

Power Distribution Units (PDUs)

You can extend the capabilities of the Compaq R6000 UPS by attaching a Compaq Power Distribution Unit (PDU) to the high current receptacle associated with load segments 1, 2, or 3. This provides 12 additional receptacles to load segments 1, 2 or 3.

The Compaq High to Low Voltage Transformer (250VA), another Compaq Power Distribution Unit, may be connected to the Compaq R6000 UPS to supply two low-voltage outlets at 250 VA. See the documentation included with each unit for Installation and Operation instructions.

You can connect your devices to the PDU using IEC-320 jumper cords (Part No. 295633-B21). To order more IEC cords, see the section in this chapter entitled, "Configuring Load Segments."

Remote Emergency Power Off (REPO) Port

The Compaq R6000 UPS Series models include a Remote Emergency Power Off (REPO) port, as required by the National Electrical Code (NFPA 70). The REPO port provides a terminus to attach controls that shut the UPS outputs down from a remote location. The REPO ports of multiple UPS units may be connected to a single switch or circuit to shut down the entire system in an emergency.

IMPORTANT:

- The REPO feature shuts down protected devices immediately and does not follow the orderly shutdown procedure initiated by Compaq Power Management Software.
 - The REPO feature will shut down devices that are operating on battery power. When the REPO switch is re-opened, the UPS will not switch to battery power until manually re-started.
-

Warranty

\$25,000 Computer Load Protection Guarantee

To back up the wide range of features offered with our UPS, Compaq provides a three-year limited warranty. In addition, Compaq offers a \$25,000 Computer Load Protection Guarantee (provided by the original equipment manufacturer).

IMPORTANT: You must fill in and return the warranty card supplied with your UPS to qualify for the \$25,000 Computer Load Protection Guarantee.

The \$25,000 Computer Load Protection Guarantee only applies in the following circumstances:

- The Compaq R6000 UPS was properly connected to utility power by a qualified electrician and remained properly connected during operation. For proper Compaq R6000 UPS wiring directions, see “Connecting the Compaq R6000 UPS to AC Branch Circuit,” in Chapter 2 of this guide.
- The Compaq R6000 UPS installation complies with all applicable electrical and safety codes specified by the National Electrical Code (NEC) Refer to Chapter 2 in this guide for applicable codes.
- The UPS is used under normal operating conditions. Users comply with all instructions and labels.
- The UPS is not damaged by accident (other than a utility power transient), misuse, or abuse.

Pre-Failure Battery Warranty

The Pre-Failure Battery Warranty, standard on all Compaq Uninterruptible Power Supplies (UPS), extends the advantage of a Compaq three-year limited warranty by applying it to the battery before it actually fails. Specifically, the Pre-Failure Battery Warranty ensures that when Compaq Power Management software notifies customers that the battery may fail, the battery is replaced free of charge under the warranty.

Compaq maintains the highest standards in the industry, as evidenced by the Compaq Pre-Failure Battery Warranty. The Pre-Failure Battery Warranty is beneficial in at least two significant ways—reduced total cost of ownership and reduced downtime.

Chapter 2

Installation

Important Safety Instructions

Save these instructions.

About This Device

This chapter serves as a guide to help qualified personnel install the Compaq R6000 UPS.



WARNING:

- The installation of options and routine maintenance and service of this product must be performed by individuals who are knowledgeable about the procedures, precautions, and hazards associated with AC Power Products (Trained Service Technicians).
 - The Compaq R6000 UPS must be connected directly to the AC Branch Circuit (AC Mains) by a licensed electrician.
 - There are no user-serviceable components inside.
-

Installation Considerations

Weight



WARNING: This product is heavier than it appears. To reduce the risk of personal injury or damage to the equipment:

68-136 kg

150-300 lb

- Observe local occupational health and safety requirements and guidelines for manual material handling.
 - Obtain adequate assistance to lift and stabilize the product during installation or removal. The product will be unstable when not fastened to the rails.
 - Remove all pluggable power supplies and modules to reduce the overall weight of the product.
-

Position



WARNING: To reduce the risk of personal injury or damage to the equipment, take the following precautions when installing the equipment:

68-136 kg

150-300 lb

The Compaq R6000 UPS and the Extended Runtime Modules (ERMs) **MUST** be installed at the bottom of the rack. If placed in rack with existing equipment, the rack must be re-configured to allow installation of UPS at the bottom of the rack.

The Compaq R6000 UPS must be mounted on the fixed rails included in the UPS package. Refer to the appropriate installation card and rack template, also shipped with your Compaq R6000 UPS kit for instructions on rack-mounting the Compaq R6000 UPS.

Outline of Installation Procedure

This chapter details the following steps required for Compaq R6000 UPS installation:

- Unpack the Compaq R6000 UPS.
- Assemble the rails in the rack.

NOTE: If installing an Extended Runtime Module (ERM) with the Compaq R6000 UPS, the ERM must be installed at the bottom of the rack, with the UPS immediately above. If the UPS is installed without an ERM, the UPS must be installed at the bottom of the rack.

- Install the Compaq R6000 UPS chassis on the rails.
- Wire the Compaq R6000 UPS. Have a licensed electrician attach the REPO port.
- Have a licensed electrician wire the UPS to utility power
- Install any optional ERMs.
- Complete the assembly of the Compaq R6000 UPS in the rack; install the batteries after the chassis is in place and all wiring is complete.
- Connect UPS communication ports to the host computers, and install any hardware option cards and power distribution units (PDUs).

NOTE: Perform installations before starting the UPS. It is possible to install options after installation of the UPS, however, the UPS will have to be shut down. This will cut off power supply protection for connected devices.

- Charge the batteries
- Place the UPS in Operate mode.

Check Battery Recharge Label

Before unpacking the Compaq R6000 UPS, check the battery recharge date specified on the Battery Recharge Date Label affixed to the shipping carton.

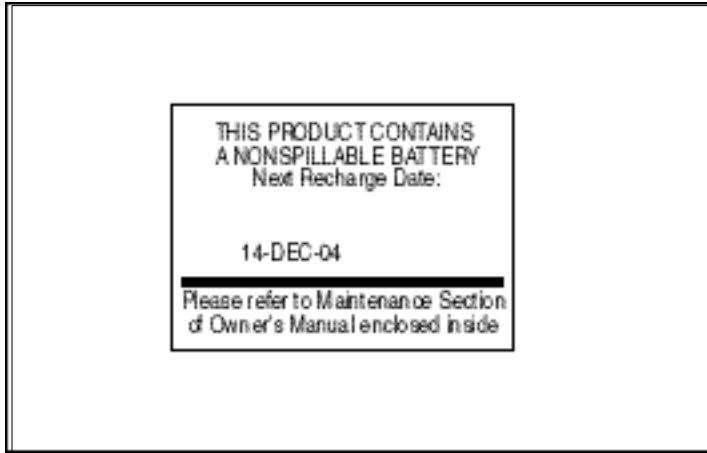

Figure 2-1. Checking the battery recharge date label

IMPORTANT: Do not use the batteries if the recharge date has passed. If the date on the Battery Recharge Date Label has passed without the batteries being recharged, contact an Authorized Compaq Service Representative.

Unpacking the UPS

Transport the Compaq R6000 UPS to its install location in the shipping carton. Unpack the UPS close to the rack where it will be assembled, following the instructions on the carton.



WARNING: To reduce the risk of personal injury or damage to the equipment,

- Only use the lift-out tray to unload the UPS.
 - Do not use the lift-out tray to transport or carry the UPS.
-

Preparing the Rack

Please refer to the Depth-Adjustable Fixed Rails Installation Card included with the unit for complete information on how to install the rails for the Compaq R6000 UPS.

Assembling the Compaq R6000 UPS

Placing UPS in rack.



68-136 kg
150-300 lb

WARNING: This product is heavier than it appears. To reduce the risk of personal injury or damage to the equipment:

- Observe local occupational health and safety requirements and guidelines for manual material handling.
- Obtain adequate assistance to lift and stabilize the product during installation or removal. The product will be unstable when not fastened to the rails.
- Remove all pluggable power supplies and modules to reduce the overall weight of the product.



68-136 kg
150-300 lb

WARNING: To reduce the risk of personal injury or damage to the equipment, take the following precautions when installing the equipment:

- The Compaq R6000 UPS and the Extended Runtime Modules (ERMs) **MUST** be installed at the bottom of the rack. If placed in rack with existing equipment, the rack must be re-configured to allow installation of UPS at the bottom of the rack.
- The Compaq R6000 UPS must be mounted on the fixed rails included in the UPS package. Refer to the appropriate installation card and rack template, also shipped with your Compaq R6000 UPS kit for instructions on rack-mounting the Compaq R6000 UPS.

NOTE: If installing an Extended Runtime Module (ERM) with the Compaq R6000 UPS, the ERM must be installed at the bottom of the rack, with the UPS immediately above. If the UPS is installed without an ERM, the UPS must be installed at the bottom of the rack.

After the rails are secured in the rack:

1. With one person on each side of the box, remove the UPS chassis from the package using the lift-out tray.
2. Gently lower the chassis to the floor in front of the rack.
3. Cut the band that holds the chassis, freeing it from the lift-out tray.
4. With one person on each side, lift the chassis to rail level and slide into place.
5. Attach the chassis to the rack using screws and cage nuts supplied with the rack.

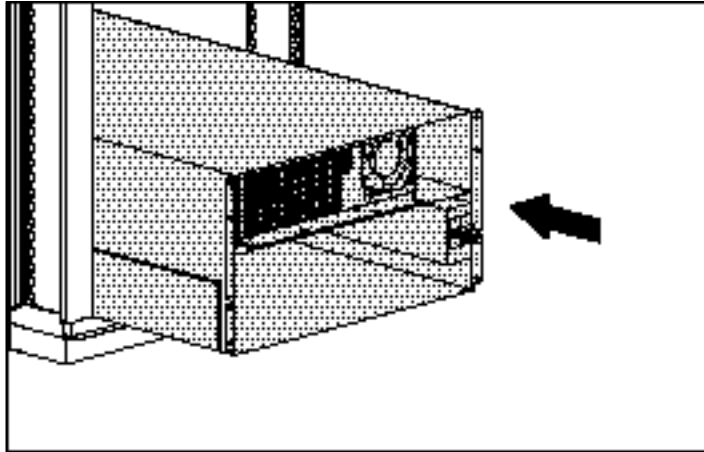

Figure 2-2. Placing chassis in rack

Wiring the Compaq R6000 UPS



WARNING: To reduce the risk of electrical shock or personal injury while performing this procedure, use a Lockout/Tagout procedure to isolate the Compaq R6000 UPS from the AC Branch Circuit (AC Mains). The Lockout/Tagout procedure should conform to local occupational safety and health regulations for the facility.

Code Compliance Information



WARNING: The Compaq R6000 UPS requires a direct connection to a dedicated AC Branch Circuit (AC Mains). Connection should only be performed by a licensed electrician in accordance with National Electrical Code (NFPA70) Article 310 in North America or in the equivalent local and national wiring regulations.



WARNING: If the Compaq R6000 UPS is to be installed in a computer equipment Room, it must also be connected to a Remote Emergency Power Off (REPO) circuit. The REPO port is designed to meet the requirements stated in National Electrical Code (NFPA 70) Article 645-10 and 11.

Connecting the Remote Emergency Power Off Switch (REPO) Port

The Compaq R6000 UPS includes a Remote Emergency Power Off (REPO) port. When properly wired, the REPO port allows the power at the UPS output receptacles to be switched off from a remote location. Local or national wiring regulations may require REPO capabilities.

The R6000 UPS must be disconnected from utility power to wire the REPO port.



WARNING: To reduce risk of personal injury or damage to equipment, the REPO port must be wired by a licensed electrician.



WARNING: In North America, the REPO port must meet the NEC (NFPA 70, Article 725) standards. The REPO port wiring must also meet all other national and local standards in the area in which it is installed.

The Compaq R6000 UPS REPO circuit is an IEC950 Secondary Extra Low Voltage (SELV) circuit. The computer room Emergency Power shutdown circuit conductors that connect to the REPO terminals must meet the requirements of an NEC Class 2 circuit or IEC950 Secondary Extra Low

Voltage (SELV) circuit and must be separated from any hazardous voltage circuits or conductors by reinforced insulation.

The computer room Emergency Power shutdown circuit must:

- Short the Compaq R6000 UPS REPO terminals
- Disconnect the Compaq R6000 UPS AC input source



WARNING: To avoid risk of personal injury or electric shock, verify that the main breaker switch is in the OFF position before wiring the REPO port.

1. Ensure the Compaq R6000 UPS is disconnected from utility power.
2. Connect Switch or Circuit to REPO Port.

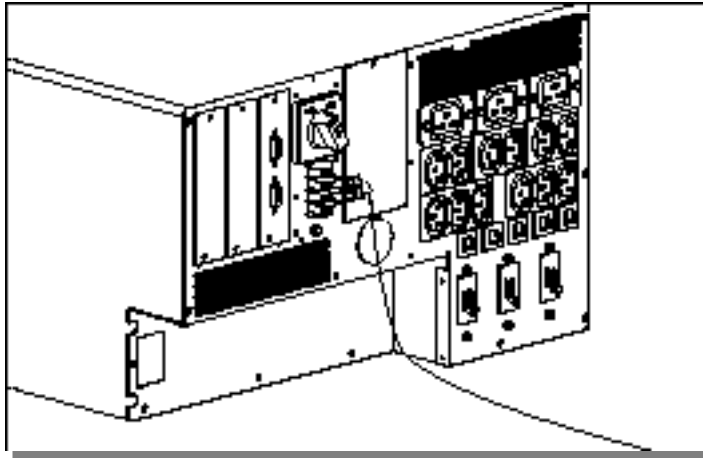

Figure 2-3. Wiring REPO port to EPO circuit

IMPORTANT: The cable that connects the R6000 to the EPO must be UL Listed, of type CL2, CL2P, CL2R or CL2X, depending on the requirements of the local installation.

3. Verify Remote Circuit is OFF. Make sure the EPO switch is in the OFF (open) position to enable power to the R6000 load segment receptacles.

Connecting the Compaq R6000 UPS to AC Branch Circuit

High Leakage Current



WARNING: To avoid the risk of electric shock due to high leakage current, earth connection (grounding) is essential before connecting the unit to an AC supply. Make sure AC Mains are turned off at the service panel before wiring the Compaq R6000 UPS.

HIGH LEAKAGE CURRENT

EARTH CONNECTION ESSENTIAL BEFORE CONNECTING SUPPLY

Risk of Fire Notice



WARNING: To reduce the risk of fire, connect the Compaq R6000 UPS only to a circuit provided with 40 A maximum branch circuit rated overcurrent protection device in accordance with the National Electrical Code (NFPA 70) and Canadian Electrical Code, C22.1.

Electrical Safety



WARNING: To reduce the risk of electrical shock or personal injury while performing this procedure, use a Lockout/Tagout procedure to isolate the Compaq R6000 UPS from the AC Branch Circuit (AC Mains). The Lockout/Tagout procedure should conform to local occupational health and safety regulations for the facility.

Requirements

The Compaq R6000 UPS requires a dedicated branch circuit meeting the following requirements:

- 40 Amp circuit with overcurrent protection
- An appropriate and readily accessible disconnect device incorporated in the fixed wiring
- 200-240 V
- single phase
- 50-60 Hz

Recommendation

Flexible metal conduit should be used when hardwiring the Compaq R6000 UPS. This will provide ease of service and maintenance of the system. Please consult a licensed electrician.

Procedure

1. Locate the input wiring entry port (❶), input wiring inspection panel (❷), and terminal block input cover (❸).

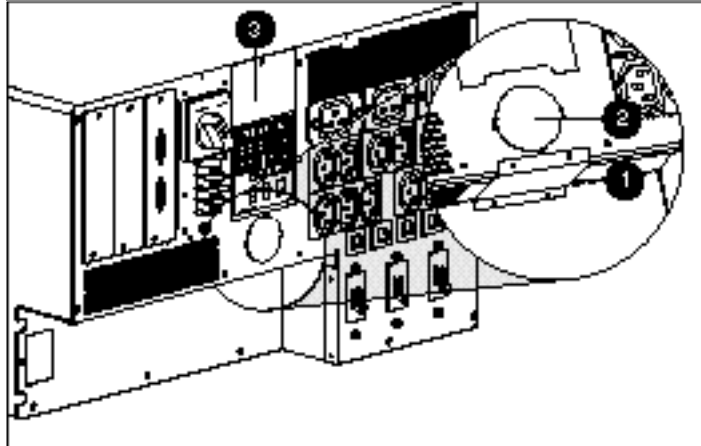

Figure 2-4. Rear panel, showing wiring entry point and inspection panel

2. Remove the terminal input block cover. Set aside but do not discard the cover; the input block cover carries the wiring diagram for the terminal block.

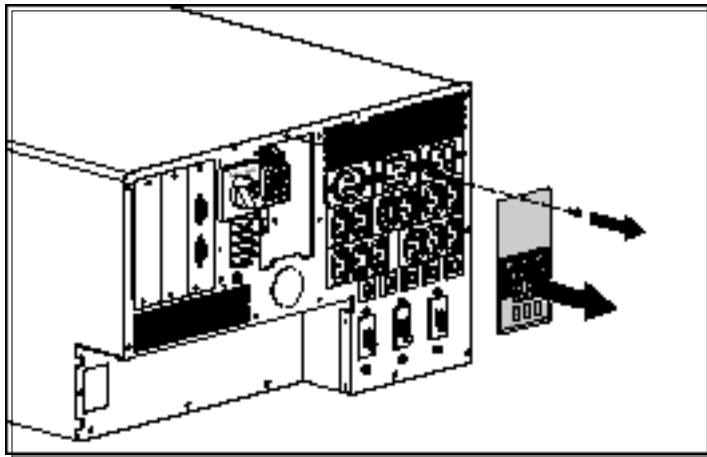

Figure 2-5. Removing terminal input block cover

3. Remove the input wiring entry port cover.
4. Pull the input wires through the conduit leading from the AC Mains, leaving about 2 ft (0.5 m) of wire hanging from the end. Attach a suitable connector to the end of the conduit.
5. Feed the wires through the wiring entry port, the entry compartment and the terminal input block compartment.
6. Connect the conduit to the panel. Measure wires, cut and strip 0.5 inch (1¼ cm) of insulation from the end of each incoming wire.
7. Following the diagram on the input cover, connect the input wires to the input terminal block connections and Ground. Ensure no loose strands remain and that the terminal connection screws are tightened to torque specifications found on the label immediately below the terminal block.

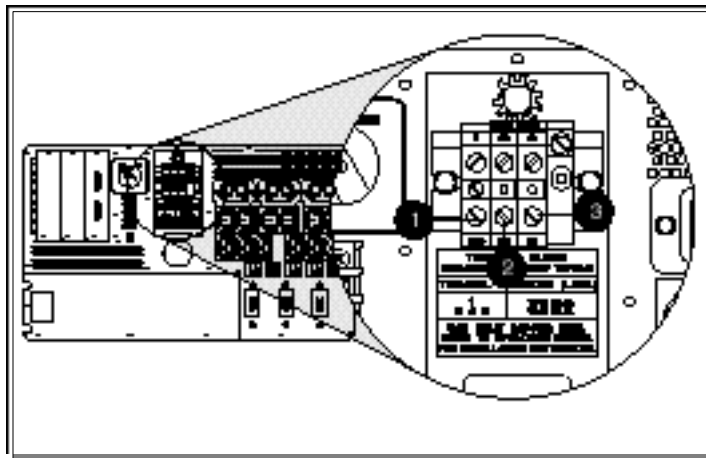





Figure 2-6. Input terminal block

Table 2-1
Input Wiring

Marking on terminal block		2	3
Connections when rated voltage is between L and N		N	L
Connections when rated voltage is between phase conductors		L2	L1

8. Replace the input terminal block cover.

Install and connect the battery packs

1. Verify battery circuit breaker is off.



WARNING: To reduce the risk of personal injury from electric shock or damage to the equipment, verify that the battery circuit breaker is in the OFF position before connecting the battery packs.

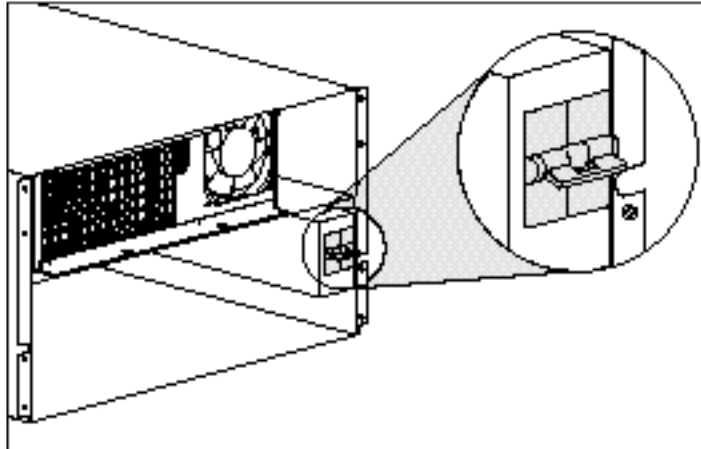

Figure 2-7. Verifying battery circuit breaker is in the OFF position

IMPORTANT: Leave the battery circuit breaker in the OFF position.

2. Slide battery packs into the UPS chassis, left battery pack first.

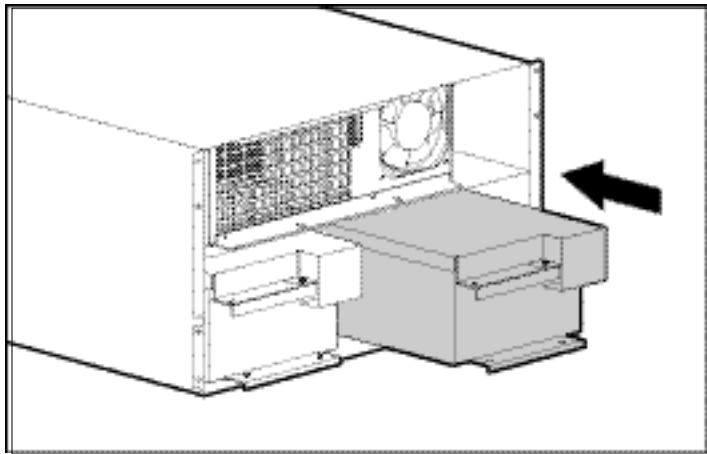

Figure 2-8. Sliding battery packs into chassis

3. For each battery pack:
 - a. Take out connector cover screw (❶).
 - b. Remove connector cover (❷) and discard.
 - c. Replace screw to secure sheet metal.

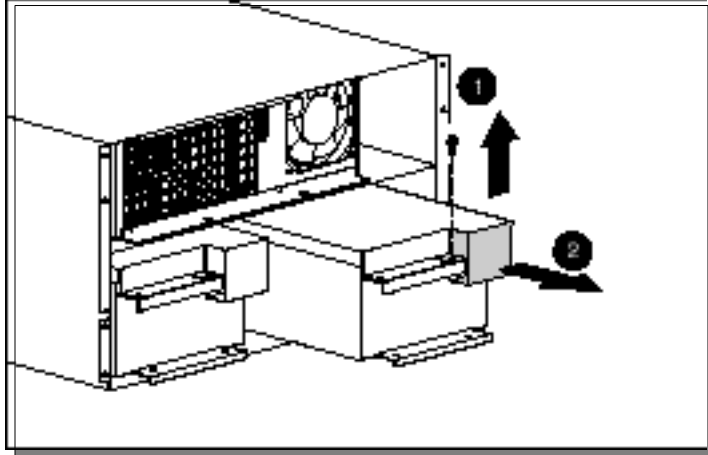

Figure 2-9. Removing battery pack connector covers

4. Secure the batteries to the chassis with screws provided in the kit.

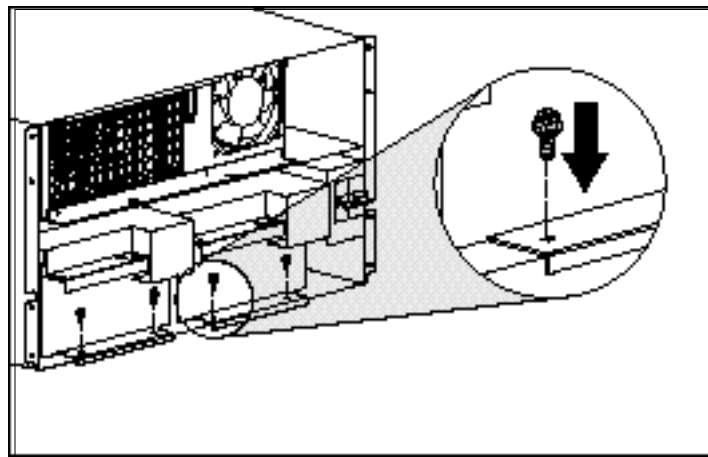

Figure 2-10. Attaching battery packs to chassis

5. Connect cables.

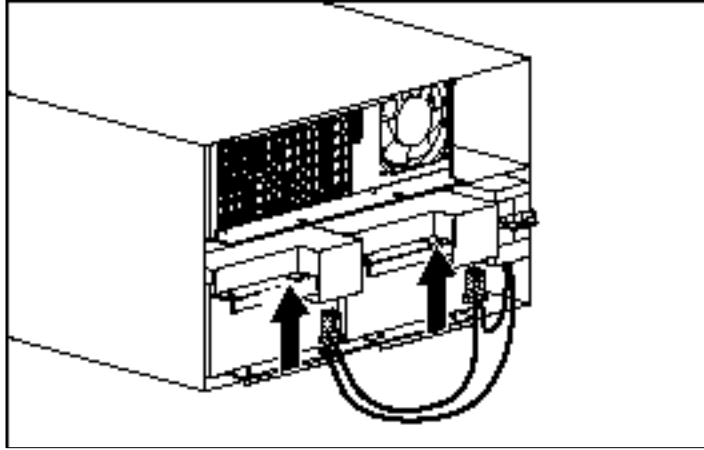

Figure 2-11. Connecting battery packs to the Compaq R6000 UPS

NOTE: When attaching battery cable connectors, the connectors will provide a positive latch into place if the release tabs are left free during attachment.

Attaching Front Top Bezel

1. Attach the connectors for the Front Panel to the Electronics Module receptacles (❶).
2. Lift the bezel into place (❷).

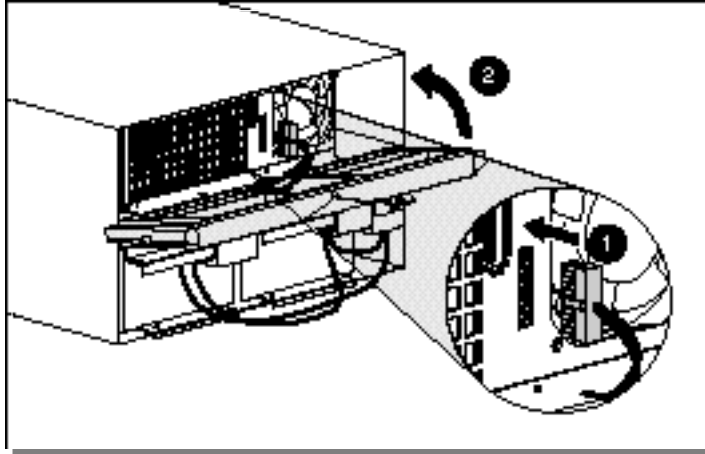

Figure 2-12. Attaching the top front bezel

3. Secure the bezel to the chassis using the captive screws on each side.

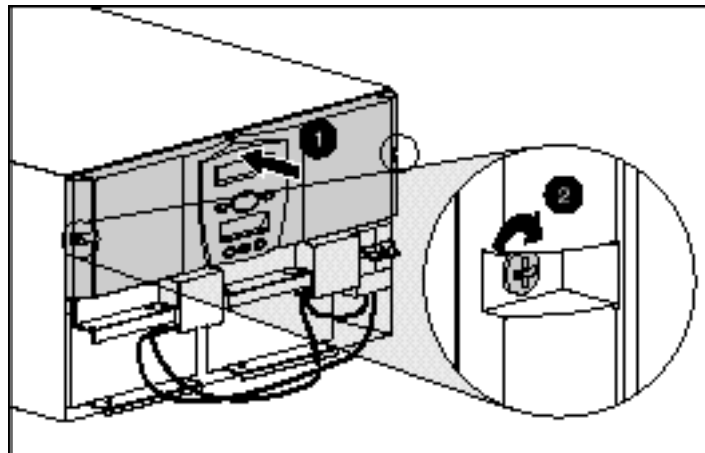

Figure 2-13. Securing the top front bezel to the chassis

NOTE: Leave lower bezel off until wiring and installation is complete.

Installing Extended Runtime Modules (ERMs)



WARNING: To reduce risk of personal injury from electric shock or damage to equipment, the Extended Runtime Modules (ERMs) must be installed by a Trained Service Technician.

The Compaq R6000 UPS provides the ability to add up to 2 ERMs, increasing the available runtime. The Compaq R6000 UPS provides greater than 8 minutes of runtime at the recommended 80% load, and one ERM will extend that runtime to greater than 18 minutes. A second ERM can provide runtimes up to 30 minutes at recommended loads.

IMPORTANT: Extended Runtime Modules must be installed by a Trained Service Technician using the Extended Runtime Module Installation Card.

Connecting Communications Ports



CAUTION: To avoid damage to the equipment, only use the communications cables with the part number:

295245-004 (Twelve-foot interface cable)

One is supplied with your kit. This UPS/Computer Interface Cable carries power and is specifically designed for UPS communications.

Connecting Communication Ports to Other Devices

Connect Port 1 of the UPS communication ports to the appropriate communication port on the host computer using a UPS/Computer Interface Cable.

In a single host computer setup, Port 2 is used for additional power management applications, such as Compaq Power Management Software, LanSafe III, FailSafe III, and OnliNet.

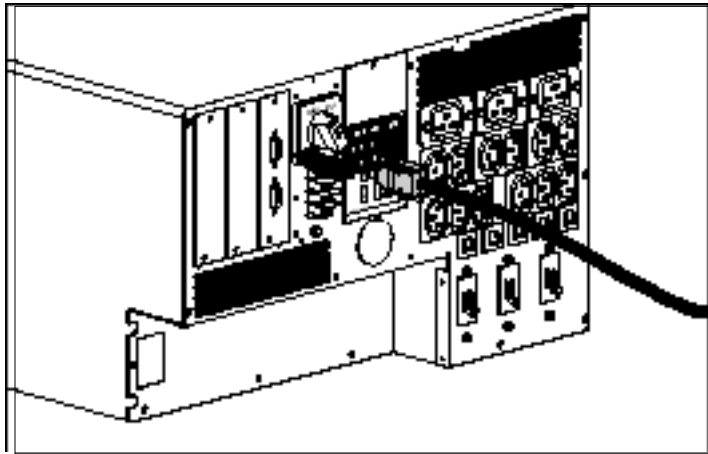

Figure 2-14. Connecting a DE9 communication cable

Installing and Connecting Communication Options

Option boards for the Compaq R6000 UPS include the Compaq Multi-Server UPS Card, the Compaq Scalable UPS Card, and the Compaq SNMP-EN Adapter. When using any of the Compaq option boards to expand the capabilities of the Compaq R6000 UPS, install the options using the instructions included with those kits.

See “Considerations” at the beginning of this guide for more information on the options available for the Compaq R6000 UPS.

Connecting Loads

Load Segments Description

The Compaq R6000 UPS has five available load segments that can be individually assigned. The numbered segments each have three receptacles. The five load segments have their own circuit breakers and are used by the software to order graceful shutdown and power-up of your network components.

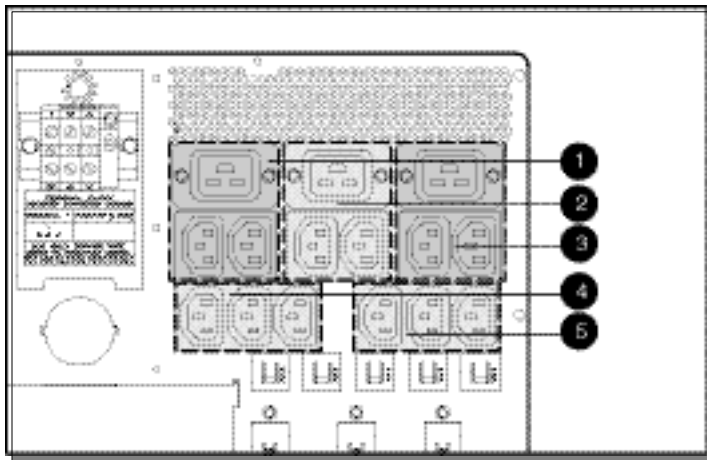

Figure 2-15. Rear panel, showing numbered load segments

- ❶ 1 IEC 320 C20, 2 IEC 320 C14
- ❷ 1 IEC 320 C20, 2 IEC 320 C14
- ❸ 1 IEC 320 C20, 2 IEC 320 C14
- ❹ 3 IEC 320 C14
- ❺ 3 IEC 320 C14

Configuring Load Segments

Considerations

Before connecting the UPS to other devices, verify the load the UPS will be carrying. Make sure that the cumulative total device Watts or VA rating (the load) does not exceed the Watts or VA rating for the UPS.

When the UPS batteries are fully charged, backup time for R6000 Series units at recommended 80% load is greater than 8 minutes without Extended Runtime Modules attached. Battery runtimes can surpass 15 minutes and more with partial loads, while ERM additions can increase runtimes up to 30 minutes, even at 80% loads. Keep this in mind when loading the UPS.

Battery runtimes may vary depending on several factors, including, but not limited to: ambient temperature; age of batteries; and, number of cycles.

Table 2-2
Load Effect on Backup Time

Load %	Estimated Backup Time
100	Greater than 6 minutes
80	Greater than 8 minutes
50	Greater than 15 minutes
80% plus 1 ERM	Greater than 18 minutes
80% plus 2 ERMs	Up to 30 minutes

NOTE: Compaq recommends the load should not exceed 80% of the Compaq R6000 UPS rated output.

Attaching the Load Segments

Attach the load equipment to the appropriate UPS output receptacles using approved power cords. See “Load Segments” in this section for receptacle configuration.

Ordering Extra Power Cords

For information on ordering additional or replacement power cords, use a browser to go to www.compaq.com; access the website’s Search feature and enter, “POWER CORDS.”

Completing the Assembly of the R6000 UPS in the Rack

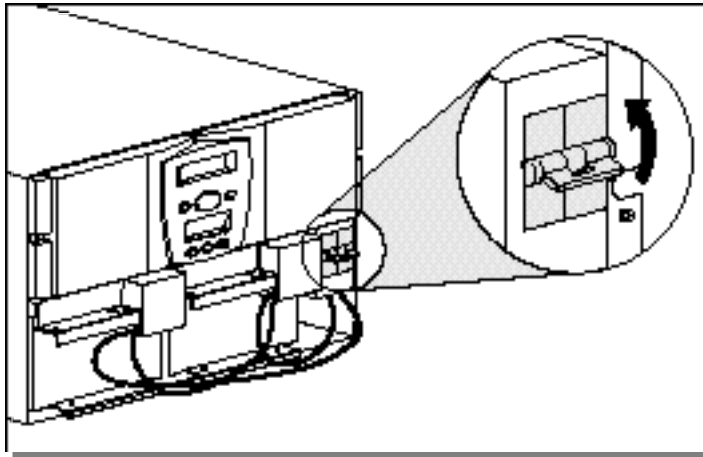

Figure 2-16. Placing the battery circuit breaker in the ON position

NOTE: If optional Extended Runtime Modules are attached, place the ERM battery circuit breakers in the ON position after the UPS circuit breaker is placed in the ON position.

Attach the front bottom bezel using the two captive screws.

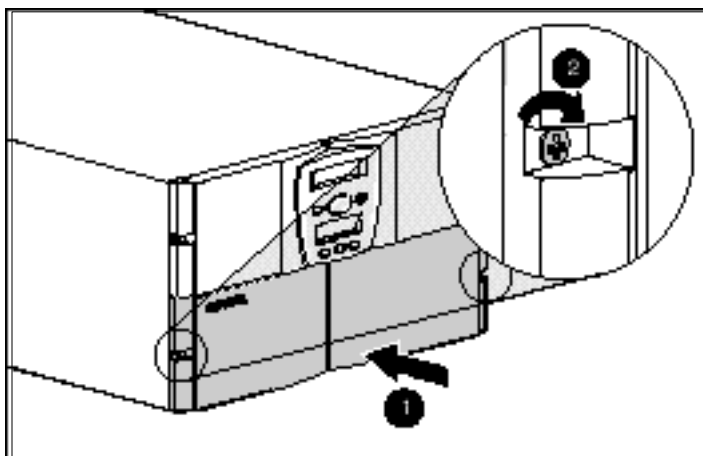

Figure 2-17. Attaching the front bottom bezel

Powering up the R6000 UPS

Turning on the Main Circuit Breaker

After a licensed electrician has the Compaq R6000 UPS properly wired to utility power, and hardware installation is complete, turn on the AC Mains at the service panel circuit. The Compaq R6000 UPS will automatically initiate a self-test. If the self-test is completed successfully, the Compaq R6000 UPS enters Standby mode, designated by the blinking green LED.

Pressing the ON button

To power up the Compaq R6000 UPS, press the ON button (●) (marked “|”) until the Green LED glows solid. Load segments will go through a staggered turn-on sequence.

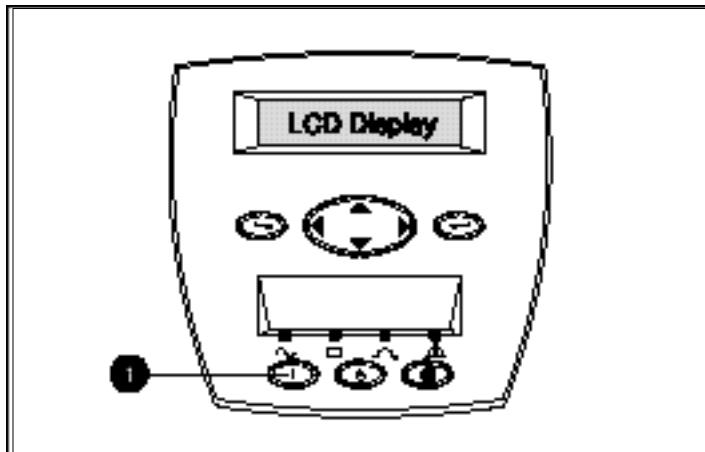

Figure 2-18. The Compaq R6000 UPS “On” button

Shutting Down the System

To shut down the system:

1. Place the UPS on Standby (See Chapter 3, “Operation”).
2. Disconnect the AC mains by opening switch or circuit breaker at the utility panel.

Charging Batteries

With the Compaq R6000 UPS in Standby Mode, allow the batteries to charge before putting the UPS into service. The battery status can be monitored using the LCD display. See Chapter 3, “Operation,” for more information on using the front panel controls and LCD display.

IMPORTANT: The battery packs will charge to:

- 90% of their capacity within 4 hours.
- 100% of their capacity within 24 hours.

Compaq recommends that you allow the batteries to charge for at least 24 hours before using them to supply backup power to your devices.

Installation is Now Complete

For information on operating the UPS, see Chapter 3, “Operation.”

For information on changing the configuration of the UPS, refer to Chapter 4, “Configuration.”

Chapter **3**

Operation

This chapter contains information on:

- Front panel controls and indicators
- Operation modes
- Initiating a self-test
- Audible Alarms

Front Panel Controls

The front panel controls and LCD display provide an easy-to-use UPS interface for setup, load control, and status monitoring. The front panel features six button controls.

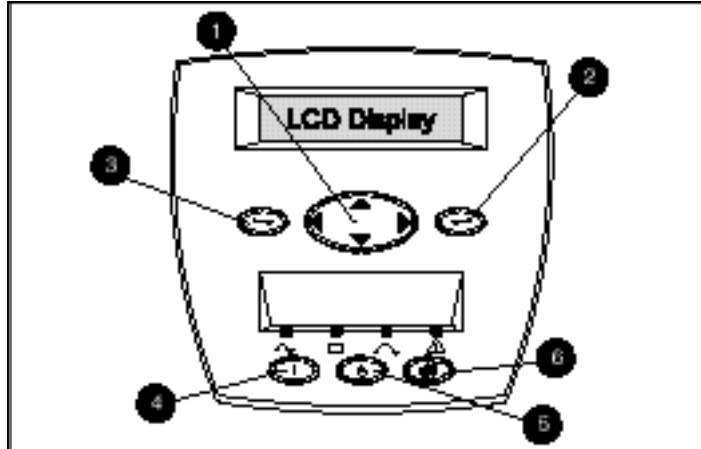

Figure 3-1 The Front Panel Controls

Control	Name	Function
①	Center	Large 4-way rocking button; used to control navigation through LCD menu structure: UP, DOWN, LEFT and RIGHT.
②	Enter	Used to navigate and select options in the LCD menu structure
③	Escape	Used to navigate and deselect options in the LCD menu structure
④	ON	Used to control status
⑤	STANDBY	Used to control status
⑥	TEST/RESET ALARM	Used to control functions

Front Panel Indicators

Front Panel LCD

The front panel has a two-line LCD display that guides the user through operation, configuration and monitoring of the Compaq R6000 UPS. See section, “Using the LCD Menu to Configure the Compaq R6000 UPS,” in Chapter 4, for configuration instructions.

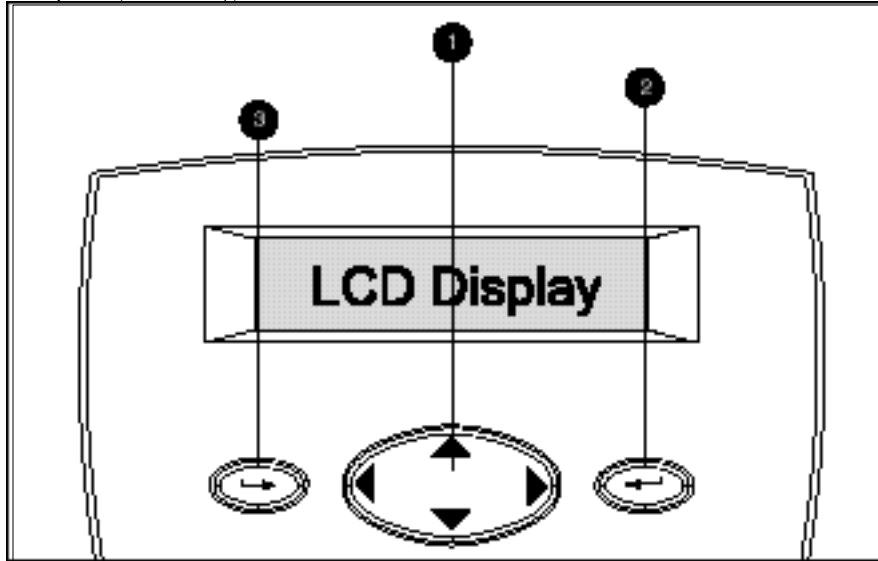

Figure 3-2. Front panel LCD display and controls

Control	Name	Function
①	Center	Large 4-way rocking button; used to control navigation through LCD menu structure: UP, DOWN, LEFT and RIGHT.
②	Enter	Used to navigate and select options in the LCD menu structure
③	Escape	Used to navigate and deselect options in the LCD menu structure

Front Panel LEDs

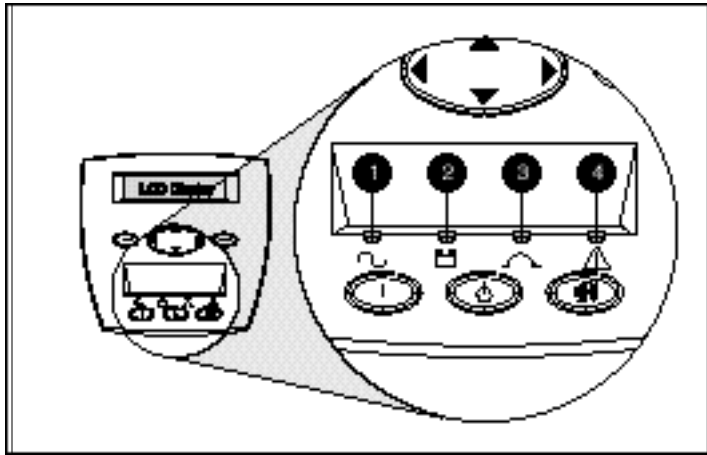





Figure 3-3. Front Panel LEDs

Ref #	Description	Symbol
①	Green LED; solid green means Operate or Bypass mode of operation (when yellow LED (③) is glowing solid), flashing green means Standby	 Smooth sine wave
②	Yellow LED; lights solidly when the UPS is on Battery	 Battery
③	Yellow LED; lights solidly in Bypass mode.	 Bypass symbol
④	Red LED is an alarm, warning of existing or potential problems.	 Warning

The front panel has 4 LEDs that indicate the status of the Compaq R6000 UPS.

Modes of Operation

The UPS has five modes of operation, indicated by the LEDs:

■ Standby Mode

- ❑ On Utility Power: green LED ❶ is flashing
- ❑ On Battery Power: yellow LED ❷ is blinking.
- ❑ Power is not available at the UPS output receptacles.
- ❑ The UPS monitors and charges batteries if required.

■ Operate Mode

- ❑ Green LED ❶ is on.
- ❑ Power is available at the UPS output receptacles.
- ❑ The UPS monitors and charges batteries if required.

■ Bypass Mode

- ❑ Green LED ❶ is on; yellow LED ❸ is on; a five-second interval audible alarm is active
- ❑ Can be enabled manually by moving the Bypass switch (on the rear panel) from NORMAL to BYPASS.
- ❑ Power is available at the UPS output receptacles.
- ❑ Batteries are not monitored or charged.

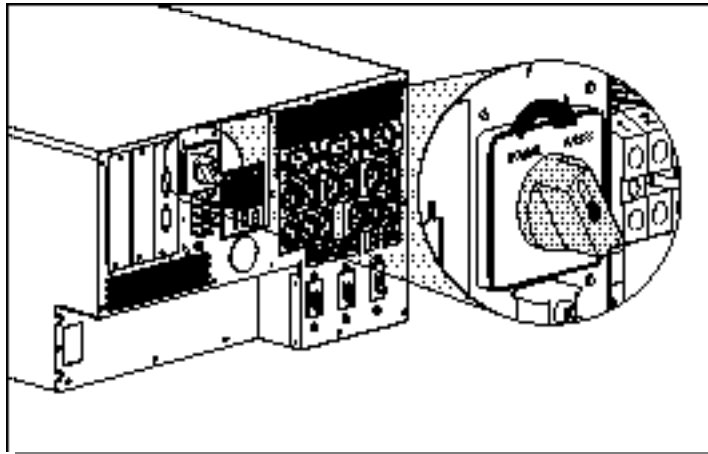

Figure 3-4. Placing the Compaq R6000 UPS in Bypass Mode

■ **Battery Mode**

- ❑ Yellow LED ② is on.
- ❑ Batteries are not being charged.
- ❑ Power is available at UPS outputs.
- ❑ Shutdown process has begun.

■ **Sleep Mode**

- ❑ All LEDs are off.
- ❑ This mode is optional and can be enabled or disabled using the LCD menu. The default value for Sleep mode is “disabled.” If SLEEP MODE is enabled, the UPS shuts down when on battery power and the load is less than 8%.
- ❑ Power is automatically restored to the output receptacles when utility power is restored.

Shutting Down the System

To shut down the system:

1. Place the UPS on Standby.
2. Disconnect the mains by opening switch or circuit breaker at the utility panel.

Initiating a Self-test

Press and hold the Test/Reset Alarm button (❶) for three seconds to initiate a self-test.

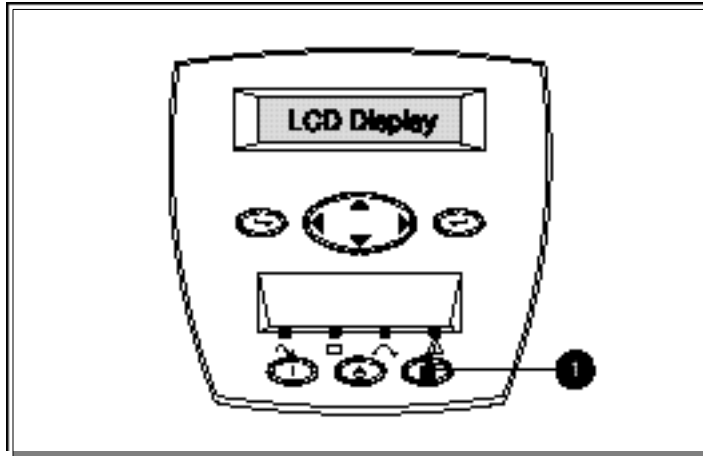

Figure 3-5. The Test/Reset Alarm button

Since a portion of the self-test requires battery power, the self-test will not be initiated if the batteries are less than 90% charged. If the Compaq R6000 UPS detects a problem, the red LED will light. If appropriate, the Compaq R6000 UPS will sound an audible alarm.

NOTE: See Chapter 6, “Troubleshooting,” for information on what to do if the self-test detects a problem.

Audible Alarm

The UPS may sound an audible alarm to warn of a problem.

To identify the problem, select *Status* from the main LCD menu, scroll to *Alarms*, then select *Alarms*. The LCD will display “X Alarms” on the top line, where X is equal to the number of alarms. The bottom row will describe the nature of the Compaq R6000 UPS alarm condition.

To view the alarms on the LCD menu, scroll to Active Alarms and press the Enter button. The possible audible alarms and their meanings are discussed in detail in Chapter 6, “Troubleshooting.”

Silencing an Audible Alarm

Press the **Test/Alarm Reset** button (●) and hold for two seconds to silence the alarm.

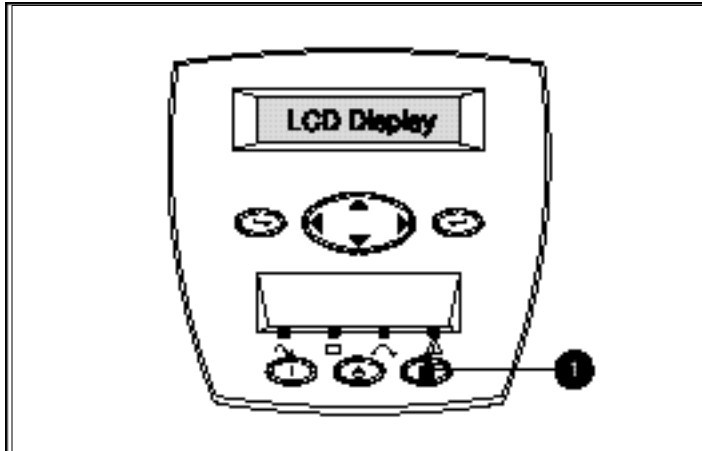

Figure 3-6. Silencing an audible alarm

IMPORTANT: Though the Alarm button will silence the audible alarm, the condition that caused the alarm still exists. See Chapter 6, "Troubleshooting," for information on what to do if the UPS detects an alarm condition.

If the condition that caused the alarm is a utility power failure, the alarm is silenced shortly after utility power is restored.

Chapter 4

Configuration

This chapter contains information on:

- Changing configuration parameters
- Using the UPS configuration to match the utility voltage
- Reading the LCD Display

Changing Configuration Parameters

The Front Panel Controls and LCD display are used to change the UPS configuration. See the section in this chapter entitled “Configuring the COMPAQ R6000 UPS Using the LCD Menu,” for configuration instructions.

Matching the Utility Voltage

Configuration parameters are used to select the UPS voltage range.

- If the utility voltage is within this range, the UPS supplies utility power to the output receptacles.
- If the utility voltage is outside this range, the UPS supplies battery power to the output receptacles. Maximize your battery life by configuring the UPS so that the utility voltage is normally within the selected voltage range.

If the utility voltage frequently varies outside the operating range, update the UPS configuration to match.

1. Select the appropriate nominal utility voltage (200, 208, 220, 230, 240 VAC, and “auto sensing,” a default of 208/230V).
2. Select the appropriate utility voltage range from the table below:

**Table 4-1
Voltage Ranges (VAC)**

Nominal Utility Voltage Level (VAC)	Normal Utility Voltage Range	Extended Utility Voltage Range
200 V Nom.	166-240 V	N/A
208 V Nom.	66-248 V	N/A
220 V Nom.	176-264 V	N/A
230 V Nom.	184-276 V	166-288 V
240 V Nom.	192-288 V	N/A

To update the configuration:

3. Have a licensed electrician measure your utility voltage.
4. Use the table above to identify the operating range that most closely matches your utility voltage.
5. Update the nominal utility voltage level and/or utility voltage range parameters as required. See the section, “Set Voltage,” in this chapter.

Configuring the COMPAQ R6000 UPS Using the LCD Display Menu

The COMPAQ R6000 UPS LCD menu has a two-line LCD display with 3-button control for up, down, left, right, Enter, and Escape. The LCD is used for configuration, monitoring, load control, and status.

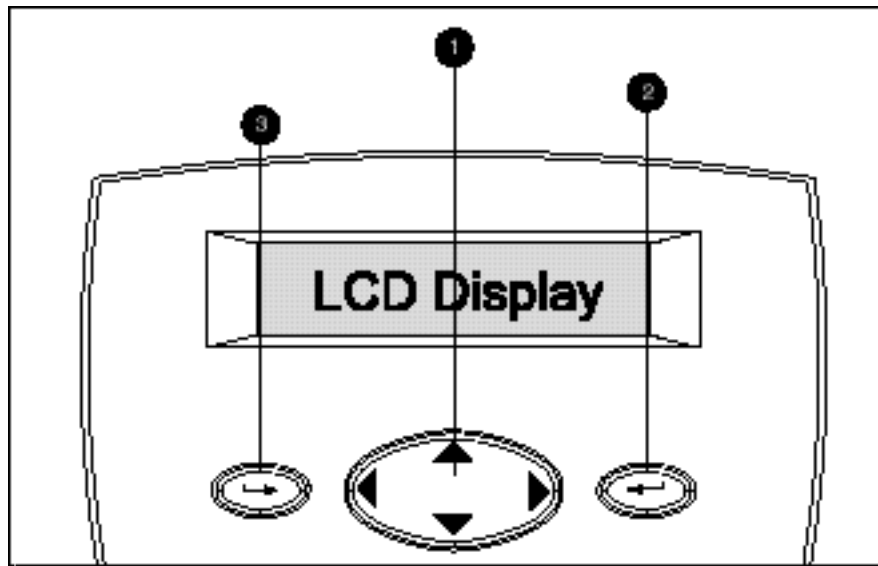

Figure 4-1. The LCD display, showing the three buttons that control it

Control	Name	Function
❶	Center	Large 4-way rocking button; used to control navigation through LCD menu structure: UP, DOWN, LEFT and RIGHT.
❷	Enter	Used to navigate and select options in the LCD menu structure
❸	Escape	Used to navigate and deselect options in the LCD menu structure

LCD Display Menu Structure

Initial Power-Up Display

When the UPS is powered up, the LCD display the Main Menu selection.

COMPAQ R6000 UPS	
→	Main Menu

The right arrow symbol (→) indicates that a sub-menu is available by pressing the Enter button on the front panel.

Top Level Main Menu

After pressing the Enter button, "Main Menu" will appear on the top line of the display. The Center button can be used to scroll through the choices displayed on the lower line of the display.

Main Menu	
→	xxxxxx

Where xxxxxx is one of the following choices in the left column (sub-menu choices are shown to the right):

Sub-Menu Choices

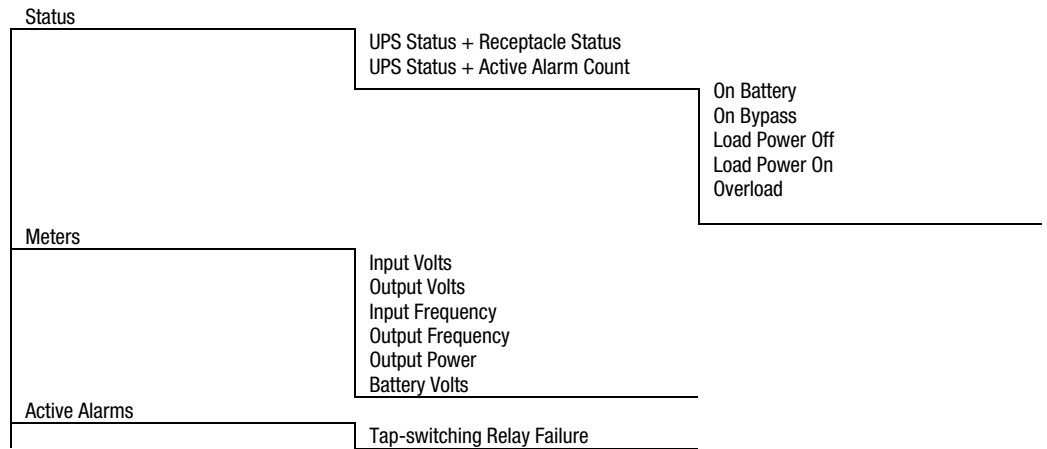

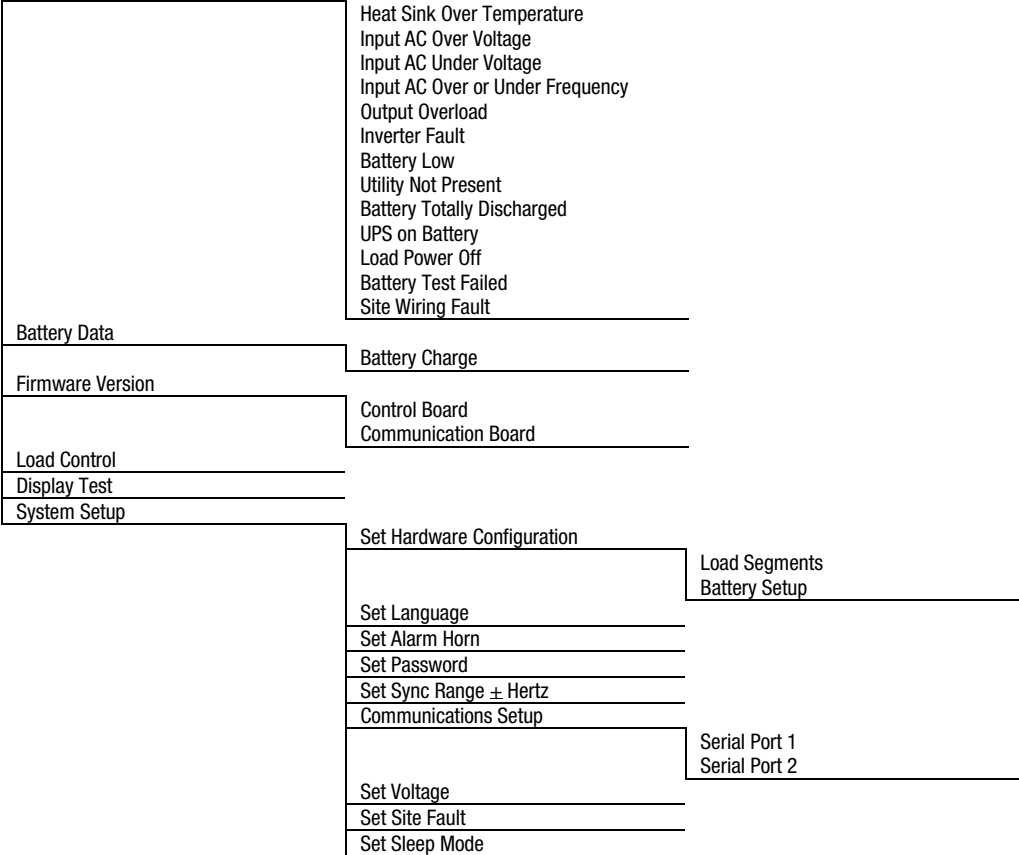

Status

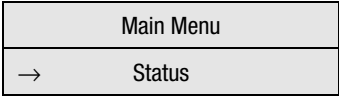

The first choice on the Main Menu is “Status.” Pressing the Enter button when “Status is displayed leads to the following sub-menu choices:

UPS Status + Load Segment status

This shows that the UPS has detected no problems. In this example, load segments 1, 4 and 5 are ON. Segments 2 and 3 are OFF.

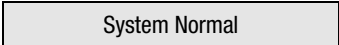

ON: 1 - - 4 5

UPS Status + Active Alarm Count

In this example, the UPS has detected no problems and there are no alarms.

System Normal
0 Alarms

On Battery

The UPS has switched from utility voltage input to battery power. “X” is the number of alarms.

On Battery
X Alarms

On Bypass

The UPS has been placed in Bypass mode. “X” is the number of alarms triggered when the UPS was switched to Bypass mode.

On Bypass
X Alarms

Load Power Off

The power feeding the UPS-protected devices has terminated. “X” is the number of alarms triggered when the load power was terminated.

Load Power Off
X Alarms

Load Power On

Utility power has been restored to the devices backed up by the UPS. “X” is the number of alarms triggered when the load power resumed.

Load Power On

X Alarms

Overload

There are so many loads attached that the UPS cannot protect them properly anymore. "X" is the number of alarms triggered when the overload occurred.

Overload
X Alarms

Meters

Main Menu
→ Meters

The next choice available on the Main Menu, is "Meters." This SubMenu provides virtual meters monitoring the UPS voltages. Scroll up and down through this menu using the Center button. If the words continue off the screen, scroll right and left to read the message.

Input Volts

The utility voltage

Input Volts
220

Output Volts

The voltage available at the UPS output receptacles

Output Volts
208

Input Frequency

The utility voltage frequency in Hertz

Input Frequency

60.00

Output Frequency

The frequency in Hertz available at the UPS output receptacles

Output Frequency
60.00

Output Power

The output power is shown in a bar graph. This example shows 120% load (overload). There are ten squares in front of the 100% line; each represents 10% load. The two squares past the line each represent 10% of overload—20% overload in all.

Output Power
■■■■■■■■■■ ■■-----

In contrast, this display shows 60% load.

Output Power
■■■■■----- -----

Battery Volts

The voltage across batteries

Battery Volts
350

Active Alarms

Main Menu
→ Active Alarms

When an alarm sounds (and the red LED lights), from the Main Menu, scroll to the active alarm count. “X” is the number of alarms detected. Press the

Enter button to step through the list of alarm descriptions. If more than 1 alarm was indicated, make sure to look at every alarm.

The alarms generated by this UPS are:

Input AC Over Voltage

If the utility voltage rises over the specified range, the UPS will buck the output voltage down, and trigger a red LED alarm signal. An audible alarm will be triggered when overvoltage reaches 120% of the nominal range setting.

X Alarms
Input AC Over Voltage

Input AC Under Voltage

If the utility voltage falls below the specified range (20% or more under voltage), the UPS will boost the output voltage up and raise an alarm. This alarm will not appear until the UPS is on battery.

X Alarms
Input AC Under Voltage

Input Over or Under Frequency

If the utility frequency suddenly changes, the UPS will raise an alarm. This only occurs when the UPS goes on battery.

X Alarms
Input Over or Under Frequency

Output Overload

If there are too many loads draining the UPS, the UPS will raise an alarm. Decrease the number of active devices attached to the UPS outputs.

X Alarms
Output Overload

Inverter Fault

The UPS raises an alarm if the inverter function does not perform as expected.

X Alarms
Inverter Fault

Battery Low

The batteries are automatically charged by the UPS when it is connected to utility voltage. Therefore, if this alarm is triggered while the UPS is on the utility voltage, the battery test has failed and the batteries must be replaced. Otherwise, it is a warning that the battery runtime is low—a 60-day warning.

X Alarms
Battery Low

Utility Not Present

When the utility voltage cuts off, the UPS sounds an alarm. The Battery LED (the left yellow LED) will light, indicating the switch to battery power. Check the utility voltage connection.

X Alarms
Utility Not Present

Battery Totally Discharged

This means there is no charge left in the battery, and the UPS can no longer power its loads. The batteries must be recharged for 24 hours before further use. If this alarm occurs when the UPS is not on battery power, the battery needs to be replaced.

X Alarms
Battery Totally Discharged

UPS on Battery

When the UPS switches to battery power, it triggers an alarm. The left yellow LED will light.

X Alarms
UPS on Battery

Load Power Off

When the UPS is no longer protecting its load devices and there is no utility voltage powering the devices, the UPS will trigger an alarm.

X Alarms
Load Power Off

Battery Test Failed

Periodically, the Compaq UPS microprocessor initiates a brief discharge cycle to check the charge level of the battery packs. If this test fails, the UPS will trigger an alarm, indicating that battery replacement is imminent.

X Alarms
Battery Self-Test Failed

Site Wiring Fault

This alarm is triggered when either there is no ground connection between utility power and the UPS, or the line and neutral connections between utility power and the UPS are reversed. This is disabled for 200V and 208V.

X Alarms
Site Wiring Fault

Battery Data

Main Menu
→ Battery Data

Also under Main Menu is **Battery Data**, displaying, in 10% increments, the amount of charge on the battery. If the UPS is in Battery mode, the graph

shows the remaining battery energy. This screen shows a battery charged to 100%.

Battery Charge

Firmware Version

This Main Menu selection displays firmware versions for UPS components. Press the Enter button to view selections.

Main Menu
→ Firmware Version

This menu selection shows the version of firmware the control board is running.

Control Board
Version 1.00

This menu selection shows the version of the firmware the communication board is running.

Communication Bd
Version 1.00

Load Control

This Main Menu selection allows the load segments to be turned On and Off.

Main Menu	
→	Load Control

When selected from the Main Menu by pressing the Enter button, Load Control displays the current status of the load segments, and allows selection of a segment using the Center button to navigate and the Enter button to select.

Load Control	
ON :1 2 3 – 5	

When a segment is selected, a confirmation display appears.

Load Control	
On	1 ON N ?

In this example, the “N” can be changed to a “Y” by using the Center button, pressing the UP/DOWN arrows; pressing the Enter button to selects the value. The display then reflects the changes, if any. In this case, there are no changes and the status display reappears:

Load Control	
ON :1 2 3 – 5	

Display Test

In this Main Menu selection, all pixels are lit to test the LCD display. “Compaq UPS Display Test” scrolls across the screen in both upper and lower display lines. The Escape button is used to exit from this test.

■■■COMPAQ UPS■■■■■■■■
■■■■■■DISPLAY TEST■■■■■■

System Setup

To change the system setup, the correct password must be entered. The six digits for the password [0-9 & A-Z] are selected using the Center and Enter buttons.

1. Choose the first digit using the Center button's UP and DOWN arrow keys.
2. Press the Center button's RIGHT arrow key to move to the next digit.
3. To change a digit, use the Center button's LEFT arrow key to go back.
4. After the entire password has been entered, press the Enter button.

NOTE: The password must be six characters long. The default password is "COMPAQ." To establish or change the password, see "Set Password," later in this chapter.

Enter Password
COMPAQ

IMPORTANT: The Password must be six characters in length. Once entered, record the password. If the password is forgotten or lost, contact an authorized Compaq Service Provider.

Set Hardware (HW) Configuration

Load Segments

This Submenu provides a means to specify the number of individually-controllable load segments (from 1 to 5).

Set HW Config
→ Load Segments

By pressing the Enter button, this Submenu appears

Load Segments
(0-5)

Battery Setup

This menu provides a means to set the Amp-Hour Rating of each cabinet, or configure the number of external battery cabinets.

Even though the menu allows settings from 1-25, choose 5 A-H for the UPS batteries, and 5 A-H for each additional ERM, using the Center and Enter buttons.

An asterisk, “*” appears by the selected value.

Battery Amp-Hr	
Internal	0-25

Set Language

The Set Language menu provides a means to select from eight different languages for the menu display, using the Center and Enter buttons. The asterisk (*) shows the current configuration.

Set Language	
*	English

The available choices are:

- Danish
- Dutch
- English
- French
- German
- Spanish
- Italian
- Japanese

Set Alarm Horn

Some of the audible alarms can be disabled, leaving only the red LED to warn of the UPS alarm. Use this menu to enable or disable the audible alarm.

Set Alarm Horn
Enable

An asterisk, “*” appears by the selected value.

Set Password

Set Password
COMPAQ

A password must be set to protect access to some of the more critical UPS operations. The six digits [0-9 & A-Z] are selected using the arrow keys.

1. Choose the first digit using the UP and DOWN arrow keys.
2. Press the RIGHT arrow key to move to the next digit.
3. To change a digit, use the LEFT arrow key to go back.
4. After the entire password has been entered, press the Enter button.

An asterisk, “*” denotes the password is set.

IMPORTANT: Record the password for future use. If the password is lost, contact a Compaq authorized service representative for help.

NOTE: The password must be six characters long. The default password is “COMPAQ.”

Set Sync Range \pm Hertz

Use this option to set the sync range using the Center and Enter buttons.

- \pm 3.0 Hertz for normal mode
- \pm 5.0 Hertz for extended mode

Set Sync Range
+/-3.0 Hz

Communications Setup

To configure a serial communication port, select Serial Port 1 or 2 first using the Center and Enter buttons.

In this example, Serial Port 1 was selected.

Comm Setup
→ Serial Port 1

Serial Port 1

Using the Center button, scroll through the menu and choose which parameter to view or set by pressing the Enter button.

Serial Port 1
→ Baud Rate

Baud Rate

The current Baud Rate is displayed next to the asterisk (*). Choose the desired rate from the list of 5 values.

Baud Rate
* 1200

- 1200
- 2400
- 4800

- 9600
- 19200

Data Bits

There are two choices for data bits: “7” or “8.”

Serial Port 1	
→	Data Bits

An asterisk, “*” appears beside the selected value.

Data Bits 1	
*	#

Stop Bits

There are two choices for stop bits: “1” or “2.”

Serial Port 1	
→	Stop Bits

An asterisk, “*” appears by the selected value.

Serial Port 1	
→	Stop Bits

Parity

Choose the desired parity from the 5 available choices.

Serial Port 1	
→	Parity

- odd
- even
- none
- mark
- space

An asterisk, “*” appears beside the selected value.

Serial Port 2

This port is configured with the same steps as shown above for Serial Port 1.

Set Voltage

The Compaq R6000 UPS must be placed in manual Bypass using the switch at the rear of the unit, and placed into Standby mode (see Chapter 3, “Operation”) to set the voltage.

The voltage that is set will appear with an “*”. Using the Center button, scroll through the voltages and choose using the Enter button. The choices are:

- 200 V
- 208 V
- 220 V
- 230 V
- 240 V
- 208/230 V Auto Sensing
- 230 V Extended

Set Voltage
208V

Set Site Fault

The two values are “Disable” or “Enable.” Use the Center button to scroll and the Enter button to select. An asterisk, “*” marks the selected value.

Set Site Fault
Enable

Set Sleep Mode

When Sleep Mode is enabled, if the UPS is supplying battery power and the load on the UPS is less than 8%, the UPS switches to Sleep mode (the UPS shuts itself off). Use the Center and Enter buttons to “Enable” or “Disable” this feature. An “*” will mark the selected value.

Set Sleep Mode
Enable

Chapter **5**

Battery Maintenance

This chapter contains information on:

- Precautions to be observed when replacing batteries
- Charging batteries
- Replacing batteries
- Disposing of used batteries
- Care and storage of batteries

Precautions

Observe these precautions when handling or connecting batteries.



WARNING: This UPS contains sealed lead-acid batteries. To reduce the risk of fire or chemical burns, adhere to the following precautions:

- Do not attempt to recharge batteries after removal from your UPS.
- Do not disassemble, crush, or puncture the batteries.
- Do not short the external contacts of the batteries.
- Do not immerse the batteries in water.
- Do not expose the batteries to temperatures higher than 60°C or dispose in fire.

Replace only with the Compaq spare designated for your UPS.



WARNING: There is a 400Vdc potential across the batteries. To avoid the risk of electrical shock, burns, or explosion, adhere to these precautions:

- Make sure that only qualified personnel handle or connect the batteries.
 - Remove watches, rings, or other metal objects prior to working with the equipment.
 - Use tools with insulated handles.
-

Charging Batteries

The R6000 automatically charges the batteries when the UPS is connected to utility power. No user intervention is needed while the UPS is in use.

- Refer to the section on “Completing the Installation,” in Chapter 2, or “Hardware Installation,” in this chapter, for information on charging the batteries when the UPS is installed.
- Refer to “Care and Storage” in this chapter for information on keeping the batteries charged while the UPS is in extended storage.

When to Replace Batteries

If the red LED flashes, check the LCD display for the type of alarm. If the alarm reads “Battery Self-test failed,” your batteries should be replaced within 30 to 60 days. The red LED will be accompanied by an audible alarm, if enabled.

NOTE: Depending on usage and environmental conditions, your batteries will last 3 to 6 years after purchase.

Verify that battery replacement is required by initiating a UPS self-test (press the Test/Reset Alarm). If the red LED is still flashing after the test, replace the batteries.

See Chapter 3, “Operation,” for information on initiating a self-test.

Pre-Failure Battery Warranty

The Pre-Failure Battery Warranty, standard on all Compaq Uninterruptible Power Supply (UPS) models, extends the advantage of a Compaq three-year limited warranty by applying it to the battery before it actually fails. Specifically, the Pre-Failure Battery Warranty ensures that when Compaq Power Management software notifies customers that the battery may fail, the battery is replaced free of charge under the warranty.

Compaq maintains the highest standards in the industry, as evidenced by the Compaq Pre-Failure Battery Warranty. The Pre-Failure Battery Warranty is beneficial in at least two significant ways—reduced total cost of ownership and reduced downtime.

Obtaining New Batteries

Compaq supplies replacement battery packs for all UPS models. Procure replacement batteries for the UPS when the LCD alarm reads “Battery Low,” indicating that new batteries will be required in 30 to 60 days.

Replacement Battery Kit part number: **401863-001**

IMPORTANT: Compaq recommends that you do not maintain an inventory of spare batteries on-site unless you implement a procedure to keep these batteries charged while in storage.

How to Replace Batteries

Use these instructions to replace the R6000 battery packs.

Before Replacing Batteries

Place the Compaq R6000 UPS in Bypass mode (See Chapter 3, “Operation”).



WARNING: To reduce the risk of personal injury, do not attempt to replace batteries unless all battery circuit breakers (UPS and any connected Extended Runtime Modules) are in the OFF position. There is a 400Vdc across the batteries.

Removing the Battery Packs

Follow this procedure to remove the battery packs:

1. Place the Compaq R6000 UPS in Bypass mode using the manual switch located at the rear of the UPS.

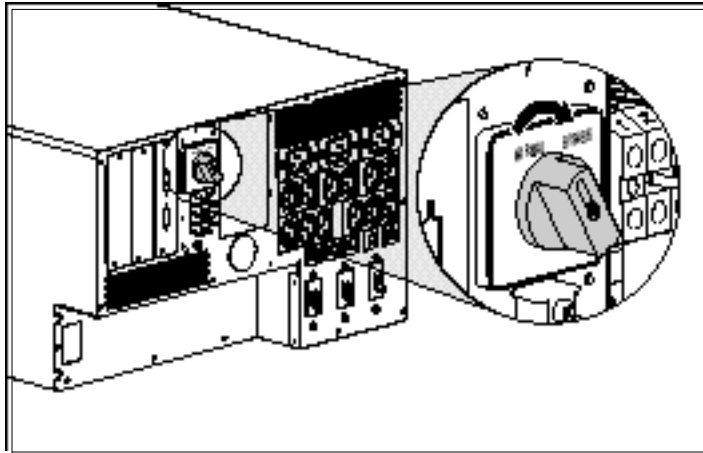

Figure 5-1. Placing the UPS in Manual Bypass mode

- Using a Philips screwdriver, remove the lower front bezel by backing off the captive screws on each side.

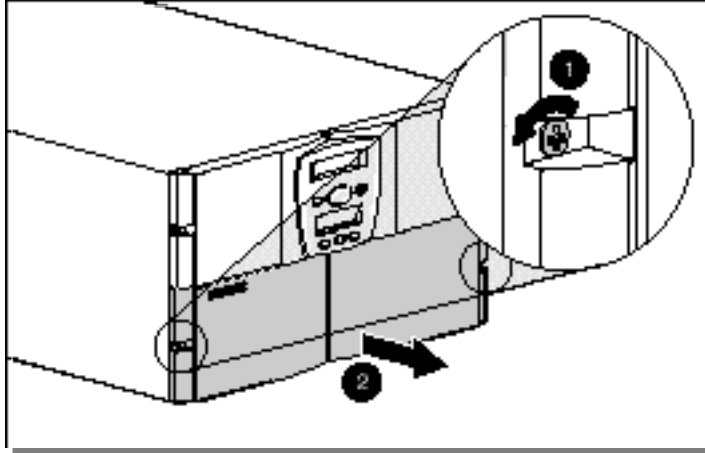

Figure 5-2. Removing screws from the lower front bezel

- Place the battery circuit breaker in the OFF position.



WARNING: To reduce the risk of personal injury, once the bezel is removed, the battery circuit breakers **MUST** be in the OFF position before continuing with the battery replacement.

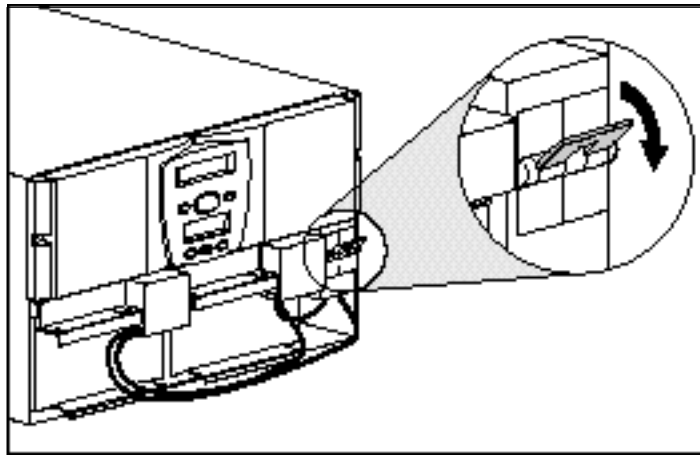

Figure 5-3. Placing the battery circuit breaker in the OFF position

4. Disconnect the battery cables. The cable connectors have release tabs on their sides that must be squeezed to allow the connectors to come free from the battery.

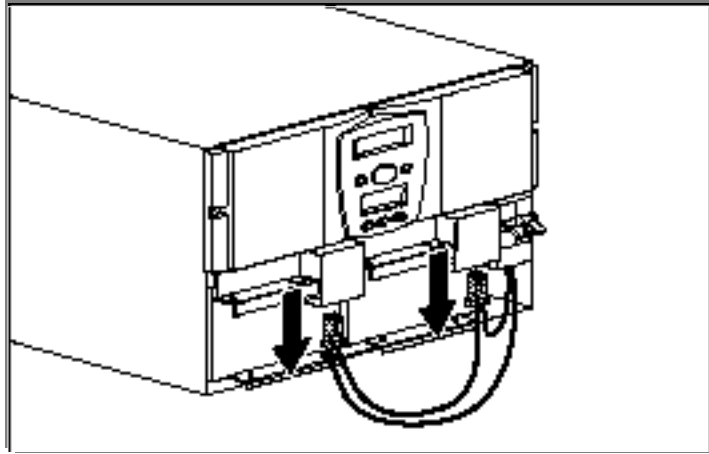

Figure 5-4. Disconnecting the battery cables

5. Remove the battery pack attachment screws using a #2 Philips screwdriver.

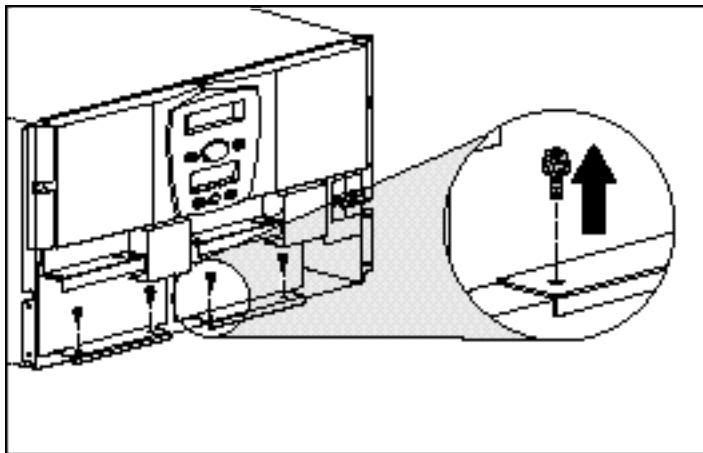

Figure 5-5. Removing the battery pack attachment screws

6. Slide out the Compaq R6000 UPS battery packs.



34 kg
75 lb

WARNING: To reduce the risk of personal injury or damage to the equipment:

- Observe local Occupational Safety requirements and guidelines for manual material handling.
- Obtain adequate assistance to lift and stabilize the assemblies during installation or removal.
- Battery Packs (2 per unit): 75 lb (34 kg)

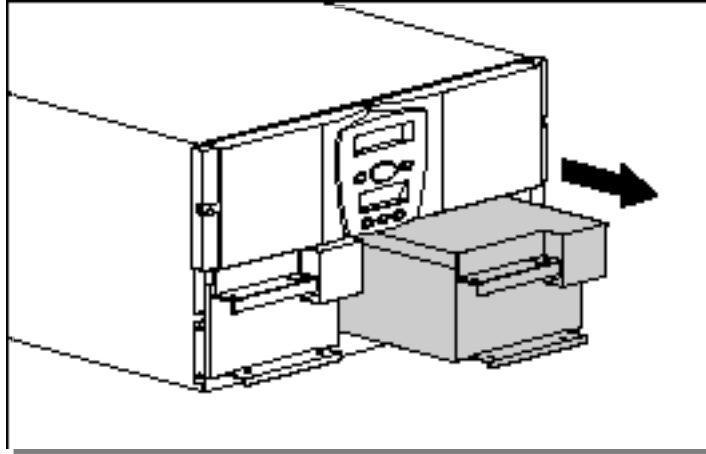

Figure 5-6. Sliding out the battery packs



WARNING: Batteries retain high voltage. As soon as the replacement batteries are safely in place in the UPS chassis, remove the battery connector covers, and place them on the batteries removed from the unit. Remove any jewelry; do not allow tools near the exposed battery connector port.

7. Set the battery packs safely aside to install the replacement batteries.

NOTE: Refer to “Disposing of Used Batteries” in this chapter for information on disposal of used batteries.

Installing New Batteries

1. Make sure the manual Bypass switch at the rear of the UPS is set to Bypass.
2. Slide in the new battery packs.
3. Remove the connector covers from the new batteries and replace the screw used to retain the connector cover in the battery housing. Place the connector covers on the used batteries, using the screws in the used battery housing.
4. Attach the battery connector cables to the new batteries.
5. Re-attach the battery pack attachment screws, securing the new battery packs to the chassis.
6. For the Compaq R6000 UPS (and any connected ERM's), place the battery circuit breaker in the ON position.
7. Reattach the lower front bezel to the UPS chassis using the captive screws at the sides.
8. Reset the manual Bypass switch at the rear of the UPS to the Normal position.
9. After installing the new batteries, press the Test/Reset Alarm button (1) to initiate a self-test.

NOTE: When re-attaching battery cable connectors, do not hold the connectors by their release tabs on the side of the connector. The connectors will provide a positive latch into place if the release tabs are left free during attachment.

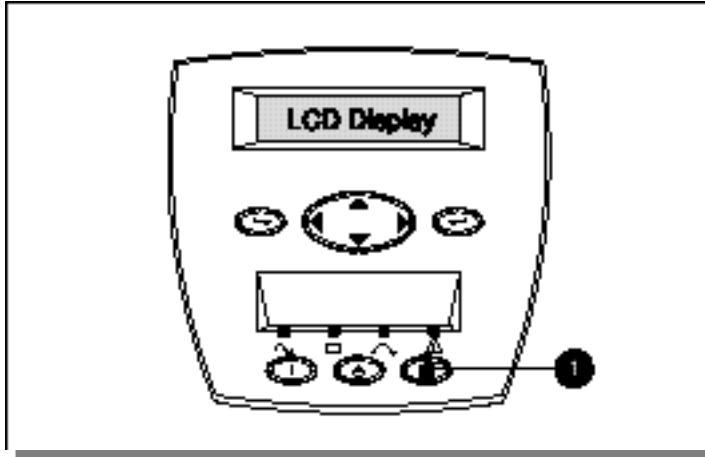

Figure 5-7. The Test/Reset Alarm button

Refer to Chapter 3, "Operation" for more information on running a self-test.

IMPORTANT: The R6000 will not execute a self-test until the batteries are at least 90% charged.

If the installation has been successful, the Compaq R6000 UPS will enter Operate mode, indicated by a solid green LED. The installation is now complete.

If the installation has not been successful, the red LED will light. If this occurs, repeat Step 4 in the procedure above to check the battery connections.

If the LED remains red, refer to the section, "Configuring the Compaq R6000 UPS Using the LCD Menu," in Chapter 4 for more information.

Disposing of Used Batteries

The replacement battery kit includes the instructions and packaging required to return used batteries to the appropriate location for disposal.

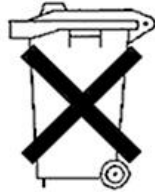

Pb

Do not dispose of used batteries with general office or household waste. Return the used module for proper disposal to either:

- Compaq, your authorized Compaq Partners, or their agents
- A recycling center that meets all local environmental standards.

Care and Storage of Batteries

To maximize the life of Compaq R6000 UPS batteries:

- Minimize the amount of time the UPS is using battery power. Match the UPS input voltage range configuration with your utility voltage. Refer to the section, “Using the LCD Menu to Configure the R6000,” in Chapter 4 for more information.
- Keep the area around the UPS clean and dust-free. If the environment is very dusty, clean the outside of the UPS regularly with a vacuum cleaner.
- Maintain the ambient temperature at 25°C (77°F).
- If storing a UPS for an extended period, recharge the batteries every six months:
 - a. Connect your UPS to utility power; refer to Chapter 2, “Installation.”
 - b. Allow the UPS to remain in Standby mode. (See Chapter 3, “Operation”)
 - c. Let the UPS run to charge the batteries for 24 hours.
 - d. Update the Battery Recharge Date label.

Extended Runtime Module (ERM) Batteries

The R6000 supports the use of two hot-pluggable Extended Runtime Modules (ERMs). The maintenance of the ERM’s batteries is the same as for that of the

Chapter **6**

Troubleshooting

This chapter provides information on the following topics:

- Responding to Audible Alarms
- Compaq R6000 UPS Trouble Indicators
- LED Alarm Configurations
- Repairing the UPS

Responding to Audible Alarms

Acknowledgement Audible Alarm

Table 6-1
Acknowledgement Audible Alarm

Audible Alarm Group	Audible Alarm Sound	Cause(s)	Action
Acknowledgement	Single short beep.	The ON or TEST button was pressed.	No action needed.
		The self or battery test completes successfully.	No action needed.

Shutdown Imminent Audible Alarm

Table 6-2
Shutdown Imminent Audible Alarm

Audible Alarm Group	Audible Alarm Sound	Cause(s)	Action
Shutdown Imminent	Single long beep.	Heat sink over temperature while on battery.	UPS will shut down in 3 seconds. Contact an authorized service provider.
		Remote Emergency Power Off. (Switch "closed," or input low.)	Check position of REPO switch. Open the REPO switch.

Shutdown within 30 seconds Audible Alarm

Table 6-3
Shutdown within 30 seconds Audible Alarm

Audible Alarm Group	Audible Alarm Sound	Cause(s)	Action
Shutdown within 30 seconds	Accelerated beeping. Begins slowly, and gains speed as the UPS approaches shutdown. UPS shuts down 30 sec after audible alarm begins.	Over-temperature.	Check the ambient temperature in the room. Refer to Appendix C, "Environmental Specifications" If the ambient temperature is within range and the over temperature alarm is chronic, contact an authorized service provider.
		Overload.	Reduce the load. See section "Connecting Loads" in Chapter 2
		Low battery.	Check the LCD display (Meters, Battery Volts)
		If a shutdown delay has been programmed, the accelerated alarm begins before the last segment shutoff.	No action needed.
		Occurs during the last minute of sleep timer if the Sleep mode is enabled.	No action needed.

Loads in Jeopardy Audible Alarm

Table 6-4
Loads in Jeopardy Audible Alarm

Audible Alarm Group	Audible Alarm Sound	Cause(s)	Action
Loads in Jeopardy	Continuous tone This audible alarm indicates loads are in jeopardy and will sound until the condition is resolved for all load groups.	Pressing the STANDBY button—placing the UPS in Standby.	Take the UPS out of Standby.
		An Overload greater than 105% while the UPS is in Operate mode or on battery.	Using the Front Panel controls, check the LCD display (Meters, Output Power). Reduce the load on your UPS to recommended levels (See “Connecting Loads” in Chapter 2.

Warning Audible Alarm

Table 6-5
Warning Audible Alarm

Audible Alarm Group	Audible Alarm Sound	Cause(s)	Action
Warning	Beeps every half second	Running out of battery power while on battery.	Check LCD display (Battery Data) and run again.
		The self-test fails.	Check LCD display (Battery Data) and run again.
		The battery test fails.	Check LCD display (Meters, Battery Voltage); if voltage is low, refer to Chapter 2, "Installation" to check battery connections, or if a battery breaker is in the ON position. Run battery test again, or replace batteries.
		Heat sink over temperature while UPS not on battery.	Check to make sure the airflow around and to the UPS is not restricted. Check the room's ambient temperature. If warning alarm still sounds, contact an authorized service provider.
		Overvoltage condition	Cycle the input power (turn the mains circuit breaker OFF, then ON. If condition remains, contact an authorized service provider.

Caution Audible Alarm

Table 6-6
Caution Audible Alarm

Audible Alarm Group	Audible Alarm Sound	Cause(s)	Action
Caution	Beeps every five seconds	On battery	Prepare for UPS shutdown.
		Load is greater than 105%, and the manual Bypass switch is turned to Bypass position.	Check manual Bypass switch on back of UPS. Turn to Normal position. Reduce load.
		Ambient over-temperature	Check air intake is not blocked and ambient room temperature is correct. If the problem still exists, contact an authorized service provider.
		Button is still being held after action is completed.	Let go of button. Make sure the button travels freely, or is not lodged.
		The UPS performs a self-test and detects a memory location error.	Turn off the UPS and call an authorized service provider.
		Site-wiring fault. (Only if the site-wiring is enabled.)	Use the Front Panel controls and LCD display to examine information on the warning. If necessary, contact a licensed electrician to check input wiring, or contact an authorized service provider.
		A self-test fails, indicated on the LCD display	Shut off Mains, wait until UPS shuts down, then turn breaker back ON and test again. If self-test fails again, contact an authorized service provider.

continued

Table 6-6

Responding to Audible Alarms *continued*

Audible Alarm Group	Audible Alarm Sound	Cause(s)	Action
Caution <i>(continued)</i>	Beeps every five seconds.	The charger fails.	Call an authorized service provider.
		A fan fails.	Call an authorized service provider.
		UPS unable to charge batteries.	See Chapter 2, "Installation" on procedures to check battery connections and make sure battery breaker is in the ON position. Run UPS for 24 hours. If condition still does not clear, contact an authorized service provider.

COMPAQ R6000 UPS Trouble Indicators

Table 6-7
Trouble Indicators

Symptom	Possible Cause	Suggested Action
UPS will not start	No utility power	Contact a licensed electrician to check power at the utility power output.
	Circuit breaker in service panel is open.	Verify that service panel breaker is in the ON position.
	Input service wire not connected.	Contact a licensed electrician to install the UPS wiring.
	REPO contacts are closed.	Open the REPO switch.
Cannot Silence Audible Alarm	Switch may be pressed and not released.	Release switch.
		Verify load, reduce load, and repeat self-test.
UPS switches frequently between battery and AC input	Input voltage in your area differs from the UPS nominal input voltage range setting	Use the Front Panel controls and LCD display to change the COMPAQ R6000 UPS nominal input voltage to match local range (see Chapter 4, "Configuration").

LED Alarm Configurations

Table 6-8
LED Alarm Configurations

LED Appearance	Meaning	Action, if necessary
Green LED flashing	UPS is in Standby.	Press the On button to power the output receptacles of the UPS.
Green LED ON	UPS is in Line Interactive Mode—Operation Mode.	No action needed.
Left yellow LED Flashing	UPS on Standby and on battery. No utility power available.	The UPS will shut down in 30 seconds.
Left yellow LED ON	Load on Battery, utility over or under voltage and/or frequency out of range.	Correct the input voltage problem, if possible. Otherwise, be prepared to lose power to the COMPAQ R6000 UPS loads when battery power is exhausted.
	UPS is shutting down.	Wait for shut down to complete. Re-boot the UPS and run self-test. If not successful, contact an authorized service provider.
	Hot start on Battery.	Re-start after checking connection to utility power.
	UPS has shut down.	Wait for shut down to complete. Re-boot the UPS and run self-test. If not successful, contact an authorized service provider.
Right yellow LED ON	UPS is in Bypass mode.	Check manual Bypass switch on rear panel. Turn to Normal position.
Red LED Flashing	Alarm condition exists.	Check alarm status on LCD.
All LEDs ON	Running self-test.	Wait for self-test to complete.
	Failure condition exists.	Contact an Authorized Service Provider.
Green LED ON, Left yellow LED ON	Self-test with load present	Allow self-test to complete.
Green LED ON, Left yellow LED Flashing	Self-test with no load present	Allow self-test to complete.

Repairing the UPS

Repairs to your UPS must be carried out by Compaq or at a Compaq-authorized service location.

Regulatory Compliance Notices

Federal Communications Commission Notice

Part 15 of the Federal Communications Commission (FCC) Rules and Regulations has established Radio Frequency (RF) emission limits to provide an interference-free radio frequency spectrum. Many electronic devices, including computers, generate RF energy incidental to their intended function and are, therefore, covered by these rules. These rules place computers and related peripheral devices into two classes, A and B, depending upon their intended installation. Class A devices are those that may reasonably be expected to be installed in a business or commercial environment. Class B devices are those that may reasonably be expected to be installed in a residential environment (i.e., personal computers). The FCC requires devices in both classes to bear a label indicating the interference potential of the device as well as additional operating instructions for the user.

The rating label on the device shows which class (A or B) the equipment falls into. Class B devices have an FCC logo or FCC ID on the label. Class A devices do not have an FCC logo or ID on the label. Once the class of the device is determined, refer to the following corresponding statement.

Class A Equipment

This equipment has been tested and found to comply with the limits for a Class A digital device, pursuant to Part 15 of the FCC Rules. These limits are designed to provide reasonable protection against harmful interference when the equipment is operated in a commercial environment. This equipment generates, uses, and can radiate radio frequency energy and, if not installed and used in accordance with the instructions, may cause harmful interference to radio communications. Operation of this equipment in a residential area is likely to cause harmful interference, in which case the user will be required to correct the interference at personal expense.

Class B Equipment

This equipment has been tested and found to comply with the limits for a Class B digital device, pursuant to Part 15 of the FCC Rules. These limits are designed to provide reasonable protection against harmful interference in a residential installation. This equipment generates, uses, and can radiate radio frequency energy and, if not installed and used in accordance with the instructions, may cause harmful interference to radio communications. However, there is no guarantee that interference will not occur in a particular installation. If this equipment does cause harmful interference to radio or television reception, which can be determined by turning the equipment off and on, the user is encouraged to try to correct the interference by one or more of the following measures:

- Reorient or relocate the receiving antenna.
- Increase the separation between the equipment and receiver.
- Connect the equipment into an outlet on a circuit different from that to which the receiver is connected.
- Consult the dealer or an experienced radio or television technician for help.

Declaration of Conformity for Products Marked with FCC Logo, United States Only

This device complies with Part 15 of the FCC Rules. Operation is subject to the following two conditions: (1) this device may not cause harmful interference, and (2) this device must accept any interference received, including interference that may cause undesired operation. For questions regarding this declaration, contact:

Compaq Computer Corporation
P. O. Box 692000, Mail Stop 510101
Houston, Texas 77269-2000, Or call (281) 514-3333

Modifications

The FCC requires the user to be notified that any changes or modifications made to this device that are not expressly approved by Compaq Computer Corporation may void the user's authority to operate the equipment.

Cables

Connections to this device must be made with shielded cables with metallic RFI/EMI connector hoods in order to maintain compliance with FCC Rules and Regulations.

Canadian Notice (Avis Canadien)

Class A Equipment

This Class A digital apparatus meets all requirements of the Canadian Interference-Causing Equipment Regulations.

Cet appareil numérique de la classe A respecte toutes les exigences du Règlement sur le matériel brouilleur du Canada.

Class B Equipment

This Class B digital apparatus meets all requirements of the Canadian Interference-Causing Equipment Regulations.

Cet appareil numérique de la classe B respecte toutes les exigences du Règlement sur le matériel brouilleur du Canada.

European Union Notice

Products with the CE Marking comply with both the EMC Directive (89/336/EEC) and the Low Voltage Directive (73/23/EEC) issued by the Commission of the European Community.

Compliance with these directives implies conformity to the following European Norms (in brackets are the equivalent international standards):

- EN50091-2-EMC
- EN60950 (IEC950) - Product Safety
- En50091-1-1-EMC

Japanese Notice

Class A/B Equipment

ご使用になっている機器にVCCIマークが付いていましたら、次の説明文を
お読み下さい。

この機器は、情報処理機器等電波障害自主規制協議会（VCCI）の基準に
基づくクラスA情報技術機器です。この機器を家庭環境で使用すると電波
妨害を引き起こすことがあります。この場合には使用者が適切な対策を講ず
るよう要求される場合があります。

VCCIマークが付いていない場合には、次の点にご注意下さい。

この機器は、情報処理機器等電波障害自主規制協議会（VCCI）の基準
に基づくクラスB情報技術機器です。この機器は、家庭環境で使用すること
を目的としています。この機器がラジオやテレビジョン受信機に近接して
使用されると、受信障害を引き起こすことがあります。
取扱説明書に従って正しい取り扱いをして下さい。

この機器は、情報処理機器等電波障害自主規制協議会（VCCI）の基準
に基づくクラスB情報技術機器です。この機器は、家庭環境で使用すること
を目的としています。この機器がラジオやテレビジョン受信機に近接して
使用されると、受信障害を引き起こすことがあります。
取扱説明書に従って正しい取り扱いをして下さい。

この機器は、情報処理機器等電波障害自主規制協議会（VCCI）の基準に
基づくクラスA情報技術機器です。この機器を家庭環境で使用すると電波
妨害を引き起こすことがあります。この場合には使用者が適切な対策を講ず
るよう要求される場合があります。

Taiwanese Notice

警告使用者：

這是甲類的資訊產品，在居住的環境中使用時，可能
會造成射頻干擾，在這種情況下，使用者會被要求採
取某些適當的對策。

Battery Replacement Notice

Your UPS is provided with a Sealed Lead Acid battery pack. There is a danger of explosion and risk of personal injury if the battery is incorrectly replaced or mistreated. Replacement is to be done by a Compaq Authorized Service Provider using the Compaq spare designated for this product. For more information about battery replacement or proper disposal, contact your Compaq Authorized Reseller or your Authorized Service Provider.



WARNING: Your UPS contains a Sealed Lead Acid battery pack. There is risk of fire and burns if the battery pack is not handled properly. To reduce the risk of personal injury,

- Do not attempt to recharge the battery
- Do not expose to temperatures higher than 60°C.
- Do not disassemble, crush, puncture, short external contacts, or dispose of in fire or water.
- Replace only with the Compaq spare designated for this product.

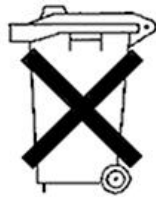

Batteries, battery packs, and accumulators should not be disposed of together with the general household waste. In order to forward them to recycling or proper disposal, return them to Compaq, your authorized Compaq Partners, or their agents.

Appendix **B**

Electrostatic Discharge

To prevent damaging the system, be aware of the precautions you need to follow when setting up the system or handling parts. A discharge of static electricity from a finger or other conductor may damage system boards or other static-sensitive devices. This type of damage may reduce the life expectancy of the device.

To prevent electrostatic damage, observe the following precautions:

- Avoid hand contact by transporting and storing products in static-safe containers.
- Keep electrostatic-sensitive parts in their containers until they arrive at static-free workstations.
- Place parts on a grounded surface before removing them from their containers.
- Avoid touching pins, leads, or circuitry.
- Always be properly grounded when touching a static-sensitive component or assembly.

Grounding Methods

There are several methods for grounding. Use one or more of the following methods when handling or installing electrostatic-sensitive parts:

- Use a wrist strap connected by a ground cord to a grounded workstation or computer chassis. Wrist straps are flexible straps with a minimum of 1 megohm \pm 10 percent resistance in the ground cords. To provide proper ground, wear the strap snug against the skin.
- Use heel straps, toe straps, or boot straps at standing workstations. Wear the straps on both feet when standing on conductive floors or dissipating floor mats.
- Use conductive field service tools.
- Use a portable field service kit with a folding static-dissipating work mat.

If you do not have any of the suggested equipment for proper grounding, have an Authorized Compaq Reseller install the part.

NOTE: For more information on static electricity, or assistance with product installation, contact your Authorized Compaq Reseller.

Appendix **C**

Specifications

This appendix provides specifications that apply to all UPS models. These include:

- Physical specifications
- Input specifications
- Output specifications
- Battery specifications
- Battery runtime
- Environmental specifications

Physical Specifications

Table C-1
Physical Characteristics

Feature		U.S.	Metric
Dimensions	Width	17.25 in	439mm
	Height	10.50 in	267mm
	Depth	24.3 in	617mm
Weight		300 lbs	136Kg

Input Specifications

Table C-2
Input Specifications

UPS Model	Frequency (Hz)	Nominal Utility Voltage (VAC)	Power Cord Supplied
R6000	50/60	200, 208, 220, 230, 240	Hard-wired to AC Mains
R6000j	50/60	200, 208, 220, 230, 240	Hard-wired to AC Mains
R6000i	50/60	200, 208, 220, 230, 240	Hard-wired to AC Mains

Output Specifications

Table C-3
Output Specifications

I. Receptacles			
UPS Model	Nominal Power Rating (VA)	Load Segment #	Output Receptacles
R6000	6000	1	2xIEC-320,C14 1xIEC-320,C20
		2	2xIEC-320,C14 1xIEC-320,C20
		3	2xIEC-320,C14 1xIEC-320,C20
		4	3xIEC-320,C14
		5	3xIEC-320,C14
R6000j	6000	1	2xIEC-320,C14 1xIEC-320,C20
		2	2xIEC-320,C14 1xIEC-320,C20
		3	2xIEC-320,C14 1xIEC-320,C20
		4	3xIEC-320,C14
		5	3xIEC-320,C14
R6000- i	6000	1	2xIEC-320,C14 1xIEC-320,C20
		2	2xIEC-320,C14 1xIEC-320,C20
		3	2xIEC-320,C14 1xIEC-320,C20
		4	3xIEC-320,C14
		5	3xIEC-320,C14

continued

Table C-3
Output Specifications *continued*

II. Output Voltage		
Utility Voltage (VAC)	Nominal Output Voltage (VAC)	Nominal Output Voltage on Battery (VAC)
200	200	204
208	208	204
220	220	230
230	230	230
240	240	230

III. Source of Utility Power	
Source	Regulation
Utility power (normal range)	±10% of nominal output voltage (within the guidelines of the Computer Business Equipment Manufacturers Association)
Utility power (extended range)	+10% to -15% of nominal output voltage and/or +5/-3% frequency. (within the guidelines of the Computer Business Equipment Manufacturers Association)
Battery power	±5% of nominal output voltage

IV. Additional Features	
Feature	Specification
On-line efficiency	96%
Voltage wave shape while on battery	Sinusoidal with less than 3% THD @ linear load
Surge suppression	High energy 6500 A peak (meets the requirements of ANSI C62.41 Category B (formerly IEEE 587))
Noise filtering	The input noise suppression is comprised of Normal Mode Filtering, Common Mode Filtering, or combination of both.

Battery Specifications

Table C-4
Battery Specifications

Feature	Specification
Type	Sealed lead-acid; maintenance-free
Voltage	Internal batteries - 12 VDC each, 360 VDC total
Charging	24 hours to full charge 4 hours to 90% capacity at default nominal utility voltage and no load

Battery Runtime

Table C-5
Load Effect on Backup Time

Load %	Estimated Backup Time
100	Greater than 6 minutes
80	Greater than 8 minutes
50	Greater than 15 minutes
80% plus 1 ERM	Greater than 18 minutes
80% plus 2 ERMs	Greater than 30 minutes

Environmental Specifications

Table C-6
Environmental Specifications

Feature	Specification
Operating temperature	10° C - 40° C (50 -104°F)
Relative humidity	20 - 80%; non-condensing
Operating altitude	Up to 3000 m (10,000 ft) above sea level
Audible noise	Less than 55 dBA @ 1 meter

Index

6

- 6000 Series
 - front panels 1-2
 - front panels illustrated 1-2
 - rear panels illustrated 1-3
 - UPSs listed 1-1
- 60-day warning 4-11

A

- AC Branch Circuit 2-1
- Accelerated Alarm 6-2
- Acknowledgement Alarm 6-2
- Active Alarm Count 4-6
- Active Alarms (LCD Menu)
 - Battery Low 4-11
 - Battery Test Failed 4-12
 - Battery Totally Discharged 4-11
 - Input AC OverVoltage 4-10
 - Input AC Under Voltage 4-10
 - Input Over or Under Frequency 4-10
 - Inverter Fault 4-11
 - Load Power Off 4-12
 - Output Overload 4-11
 - procedure 4-10
 - Site Wiring Fault 4-12
 - UPS on Battery 4-12
 - Utility Not Present 4-11

- alarm *See* audible alarm
- ambient temperature 6-3
- Amp-Hour Rating
 - setting 4-17
- Assembling the R6000 2-5
- audible alarm
 - features 3-7
 - five-second (Bypass) 3-5
 - responding to 3-8
 - silencing
 - requirement to address alarm condition 3-8
- audible alarms 6-1
 - enabling or disabling 4-18
- auto sensing 4-2

B

- batteries
 - care and storage *See* Care and storage
 - charging 5-10
 - charging 2-24
 - no user intervention required 5-2
 - charging rates vs. time 2-24
 - charging
 - recommendations 2-24
 - Compaq Power Management Software monitoring 5-3
 - Compaq three-year limited warranty 5-3

- disposing of used
 - batteries 5-10
- life expectancy 5-3
- new
 - part number 5-3
 - when to obtain 5-3
- precautions when handling or connecting 5-2
- Pre-Failure Battery Warranty 5-3
- recharge date *See* Battery Recharge Date label
- runtime specifications C-5
- self-test after replacement 5-9
- warranty replacement 1-15
- when to replace 5-3
- battery
 - "Battery Totally Discharged" alarm 4-12
 - energy graph display (LCD Menu) 4-13
 - replacement kit part number 5-3
 - replacing 5-4
 - specifications C-5
- battery cabinets
 - configuring on LCD Menu 4-17
- battery cable connectors 2-15
 - release tabs 5-8
- battery cables 2-15
 - disconnecting 5-6
- Battery Charge 4-13
- Battery circuit breaker 5-5
- battery circuit breaker, *Illus.* 2-13
- battery connector covers
 - replacing on used batteries 5-7
- Battery Data (LCD Menu) 4-13
- battery energy
 - graph *See* Battery Data (LCD Menu)
- battery kit part number (replacement) 5-3
- Battery life
 - maximizing 4-2
- Battery Low (LCD Menu) 4-11
 - replacing batteries 5-3

- battery maintenance
 - care and storage *See* Care and storage
- Battery Mode 3-6
- battery packs
 - replacing 5-4
 - weight, warning 5-7
- Battery Recharge Date label
 - where to find the label 2-4
- battery replacement
 - verifying need 5-3
- battery runtime
 - alarm 4-11
- battery self-test
 - failure alarm 4-11
- Battery Setup (LCD Menu) 4-17
- battery status
 - monitoring 2-24
- Battery Test Failed (LCD Menu) 4-12
- battery test fails 6-5
- Battery Totally Discharged (LCD Menu) 4-11
- Battery Volts (LCD Menu) 4-9
- Baud Rate 4-19
- Beep every five seconds 6-6
- Beep every half second 6-5
- bucking the output voltage 4-10
- button controls 3-2
- Bypass mode 3-5

C

- cable connectors
 - release tabs 5-6
- cables
 - serial communications
 - cable 2-18
 - UPS-Computer Interface Cable 2-18
- Canadian Electrical Code C22.1 2-9
- care and storage
 - ambient temperature 5-10
 - charging stored batteries 5-10
 - preventive maintenance 5-10
- Caution Alarm 6-6

- Center button 3-2
- changing batteries 5-1
 - precautions when handling or connecting 5-2
- charger failure 6-7
- charging the batteries
 - after installation 2-24
 - in storage 5-10
- comm port *See* communications port
- communication board
 - reading firmware version (LCD Menu) 4-13
- communication port
 - features 1-4
- communications port
 - overview 1-4
- Communications setup (LCD Menu)
 - baud rate 4-19
 - data bits 4-20
 - parity 4-21
 - stop bits 4-20
- Communications Setup (LCD Menu) 4-19
- Compaq authorized reseller x
- Compaq High to Low Voltage Transformer (250VA) 1-13
- Compaq Multi-Server UPS Card 2-18
- Compaq Power Distribution Unit (PDU) 1-13
- Compaq Power Management Software
 - capabilities 1-7
 - example of shutdown sequence 1-7
 - integration with Compaq Insight Manager 1-7
 - overview 1-7
 - using a Multi-Server UPS Card 1-10
 - using a Scalable UPS Card 1-11
- Compaq Power Products Software Reference Guide 1-8
- Compaq recommended load 1-13

- Compaq Scalable UPS card *See* option cards
- Compaq Scalable UPS Card 2-18
- Compaq SNMP-EN Adapter 2-18
- Compaq three-year limited warranty 5-3
- Compaq website x
- Compaq Website 2-21
- conduit, flexible metal 2-10
- configuration 3-3
 - changing 4-1
 - using the LCD Display Menu 4-3
- connecting cables
 - serial communications cable 2-18
 - UPS-Computer Interface Cable 2-18
- Connecting UPS to AC Mains 2-1
- connector cover 2-13
- Continuous Tone 6-4
- control board
 - reading firmware version (LCD Menu) 4-13
- controls and indicators *See* rear panel, indicators. *See* front panel, indicators

D

- Danish 4-17
- Data Bits 4-20
- DE9 Communication Port 1-4
- dedicated branch circuit 2-9
- Depth-Adjustable Fixed Rails Installation Card 2-4
- disconnect device 2-9
- Display Test 4-15
- disposing of used batteries
 - after replacing batteries 5-7
- Dutch 4-17

E

- Electronics Module
 - receptacles 2-16
- English 4-17

- Enter button 3-2
- environmental specifications C-6
- ERM *See* Extended Runtime Module
 - weight, warning 5-7
- Escape button 3-2
- Extended Runtime Module
 - weight, warning 5-7
- Extended Runtime Module (ERM)
 - Batteries 5-11
- Extended Runtime Module,
 - Illus. 1-13
- Extended Runtime Modules
 - circuit breaker engagement sequence 2-22
 - Estimated Backup Times 2-20
 - increased runtimes at 80% load 2-17
 - installing 2-17
 - installing, Trained Service Technician required 2-17
- Extended Runtime Modules,
 - Overview 1-13

F

- FailSafe III
 - overview 1-7
- fan failure 6-7
- Firmware Version (LCD Menu) 4-13
- French 4-17
- front bottom bezel
 - attaching 2-22
- front panel
 - illustrated 1-2
 - indicators 3-4
- front panel controls
 - illustrated 3-2
- front panel LCD 3-3
- front panel LCD display
 - illustrated 3-3
- front panel LED display 1-5
- front panel LEDs
 - descriptions 3-4
 - illustrated 3-4
 - symbols 3-4

- front top bezel
 - attaching 2-16

G

- German 4-17
- getting help ix
- green LED 3-4
 - flashing 3-5
 - successful battery self-test 5-9
- Green LED
 - solid in Bypass mode 3-5
 - solid in Operate Mode 3-5
- Green LED flashing 6-9
- Green LED on 6-9
- Grounding Methods B-2
- guarantee *See* warranty

H

- hardware options cards *See* option cards
- hazards 2-1
 - associated with AC Power Products 2-1
- Heat sink over temperature 6-2
- help
 - additional sources ix
 - Compaq authorized resellers, telephone numbers x
 - Compaq website x
 - technical support telephone numbers ix
- High Leakage Current 2-9
- High to Low Voltage Transformer (250VA) 1-8, 1-13
- <http://www.compaq.com> x

I

- icons
 - symbols on equipment viii
- IEC-320 jumper cords 1-13
- IEC950 Secondary Extra Low Voltage (SELV) circuit 2-7
- indicators *See* front panel, indicators

- Input AC Over Voltage
 - audible alarm 4-10
 - Input AC Over Voltage (LCD Menu) 4-10
 - Input AC Under Voltage (LCD Menu) 4-10
 - Input Frequency (LCD Menu) 4-8
 - Input Over or Under Frequency (LCD Menu) 4-10
 - input specifications C-2
 - Input Volts (LCD Menu) 4-8
 - Input Wiring 2-12
 - input wiring entry port
 - illustrated 2-10
 - input wiring inspection panel
 - illustrated 2-10
 - installation
 - attaching chassis to rack 2-6
 - conduit, flexible metal 2-10
 - Extended Runtime Module
 - position 2-5
 - fixed rail requirement 2-5
 - High Leakage Current 2-9
 - installation card 2-2
 - installing options 2-3
 - installing the fixed rails *See*
 - Depth Adjustable Fixed Rails Installation Card
 - lifting and stabilizing 2-2, 2-5
 - lift-out tray 2-4
 - Lockout/Tagout 2-7
 - mounting on fixed rail
 - requirement 2-2
 - of options, requirement for
 - Trained Service Technician 2-1
 - placing UPS in rack 2-5
 - position at bottom of rack 2-3
 - position considerations 2-2
 - positioning requirements 2-5
 - rack template 2-2
 - reducing overall weight 2-2
 - reducing weight 2-5
 - removing pluggable power supplies 2-2, 2-5
 - requirement for two person lift 2-5
 - Risk of Fire Notice 2-9
 - self test
 - automatic initiation on power up 2-23
 - transporting R6000 to install
 - location 2-4
 - weight considerations 2-2
 - Installation Card 2-4
 - Installation Procedure 2-3
 - installing a UPS
 - checking the load 2-20
 - completing the
 - installation 2-24
 - Standby mode 2-24
 - connecting the devices 2-20
 - connecting the REPO port 2-7
 - cumulative total device Watts or VA rating 2-20
 - starting up the UPS
 - checking the Battery Recharge Date label 2-4
 - Installing and connecting battery packs 2-12
 - Installing Extended Runtime Modules (ERMs) 2-17
 - Installing New Batteries 5-8
 - installing options 2-3
 - Inverter Fault (LCD Menu) 4-11
 - Italian 4-17
- J**
- Japanese 4-17
- L**
- LanSafe III
 - overview 1-7
 - LCD Display Menu
 - configuration 4-3
 - navigation 4-3
 - LED Alarm Configurations 6-8
 - LED display *See* front panel, indicators
 - licensed electrician 2-7, 2-10, 4-2
 - lift-out tray 2-4
 - using 2-5

- Load Control 4-15
- Load Control (LCD Menu) 4-15
- Load Effect on Backup Time 2-20
- Load Power Off (LCD Menu) 4-7, 4-12
- Load Power On (LCD Menu) 4-7
- load segments
 - attaching loads 2-20
 - description 2-19
 - displaying current status 4-15
 - illustrated 2-19
 - specifying number 4-16
 - staggered turn-on sequence 2-23
- Load Segments (LCD Menu) 4-16
- Loads in Jeopardy Alarm 6-4
- Lockout/Tagout 2-7, 2-9
- lower front bezel
 - removing 5-5
- low-voltage outlets
 - attaching using High to Low Voltage Transformer 1-13

M

- Main Menu (LCD Menu) 4-4
- manual material handling
 - observing guidelines 2-2
- matching, utility voltage with UPS configuration 4-2
- Meters (LCD Menu) 4-8
- MIB 1-12
- modes of operation *See* Standby mode, Operate mode, Bypass mode, Sleep mode

N

- National Electrical Code 2-9
 - (NFPA 70) requirements when wiring REPO Port 1-14 (NFPA70)
 - Article 310 or equivalent 2-7
 - REPO wiring standards 2-7
 - requirements for REPO circuit 2-7
 - warranty requirements 1-14

- NFPA 70, Article 725 2-7
- no ground connection
 - alarm *See* Site Wiring Fault (LCD Menu)

O

- occupational health and safety regulations 2-9
- occupational health and safety requirements 2-5
 - observing 2-2
- occupational safety and health regulations
 - in Wiring procedure 2-7
- On Battery (LCD Menu) 4-6
- ON button 2-23, 3-2
- On Bypass (LCD Menu) 4-6
- Onlinet 1-7
- OnliNet, supporting SNMP 1-12
- Operate mode 3-5
- operating on battery power
 - consequences of REPO switch shutdown 1-14
- option boards *See* option cards
- option card
 - Multi-Server UPS Card
 - overview 1-10
 - overview 1-8
 - protecting multiple servers 1-10
 - Scalable UPS Card
 - overview 1-11
 - scaling up UPS capabilities 1-11
- Output Frequency (LCD Menu) 4-8
- Output Overload (LCD Menu) 4-11
- Output Power (LCD Menu) 4-9
 - reading bar graph 4-9
- output specifications C-3
- Output Volts (LCD Menu) 4-8
- over temperature alarm 6-3
- overcurrent protection device
 - requirement in circuit 2-9
- Overload 6-4

Overload (LCD Menu) 4-7
 overview
 battery maintenance 5-1
 specifications C-1
 troubleshooting 6-1
 Overvoltage 6-5

P

Parity 4-21
 password
 default 4-16, 4-18
 entering in LCD Display 4-16
 lost or forgotten 4-18
 procedure 4-16
 requirement 4-18
 requirements for System
 Setup 4-16
 PDU High Voltage Models Part
 Numbers 1-8
 physical characteristics C-2
 physical specifications C-2
 Placing in Bypass mode 5-4
 Power Cords 2-21
 Power Distribution Unit
 (PDU) 1-13
 Power Management Software *See*
 Compaq Power Management
 Software
 Power MIB 1-12
 power up 2-23
 Power-Up Display (LCD
 Menu) 4-4
 precaution
 handling or connecting
 batteries 5-2
 Pre-Failure Battery Warranty 1-15,
 5-3
 benefits 5-3
 Preparing the Rack 2-4
 protecting access to critical UPS
 operations *See* Set Password
 (LCD Menu)

R

range *See* voltage range

rear panel
 illustrated 1-3
 recharge date *See* Battery
 Recharge Date label
 red LED 3-4
 battery self-test failure 5-9
 red LED flashing 6-9
 Remote Emergency Power Off
 conductors requirements 2-7
 connecting 2-7
 implications when UPS on
 battery power 1-14
 managing multiple UPSs 1-14
 National Electrical Code
 (NFPA 70) Article 645-10
 and 11 2-7
 no orderly shutdown 1-14
 overview 1-14
 performance requirements 2-7
 REPO cable requirements 2-8
 requirement 2-7
 repairing the UPS 6-10
 replacing batteries
 disposing of used batteries 5-7
 powering down the UPS 5-4
 procedure 5-4
 replacement battery kit part
 number 5-3
 REPO *See* Remote Emergency
 Power Off
 reversed connections
 alarm *See* Site Wiring Fault
 (LCD Menu)
 right arrow symbol (LCD
 Menu) 4-4
 Risk of Fire Notice 2-9
 RJ-45 receptacle viii
 routine maintenance
 requirement for Trained
 Service Technician 2-1
 RS-232 port *See* DE9
 communication port

S

safety *See* Warnings
 Battery Maintenance 5-2

- High Leakage Current 2-9
 - in Wiring 2-7
 - Risk of Fire Notice 2-9
 - Safety Instructions
 - Installation 2-1
 - self-test 6-5
 - after battery replacement 5-9
 - automatic initiation on Power up. 2-23
 - initiating *See* Test/Reset Alarm button
 - memory location error 6-6
 - requirement for 90%-charged batteries 3-7
 - requirements for battery charge 5-9
 - serial port *See* DE9
 - communication port
 - Serial Port 1 4-19
 - Serial Port 2 4-21
 - Set Alarm Horn (LCD Menu) 4-18
 - Set Hardware (HW) Configuration (LCD Menu) 4-16
 - Set Language (LCD Menu) 4-17
 - Set Password (LCD Menu) 4-18
 - Set Site Fault (LCD Menu) 4-22
 - Set Sleep Mode (LCD Menu) 4-22
 - Set Sync Range \pm Hertz (LCD Menu) 4-19
 - Set Voltage (LCD Menu) 4-22
 - shutdown 2-23
 - by REPO switch 1-14
 - shutdown delay 6-3
 - Shutdown Imminent 6-2
 - Shutdown Imminent Alarm 6-2
 - shutdown sequence
 - specifying 1-7
 - Shutdown within 30 seconds
 - Alarm 6-3
 - Shutting Down the System 2-23, 3-6
 - Single long beep 6-2
 - Single Short Beep Alarm 6-2
 - Site Wiring Fault (LCD Menu) 4-12
 - disabled for 200V and 208V 4-12
 - Sleep mode 6-3
 - Sleep Mode
 - explained 3-6
 - SNMP Support 1-7
 - SNMP-EN Adapter Kit 1-12
 - SNMP-EN Adapter Part Number 1-8
 - SNMP-EN Adapter, Illus. 1-12
 - SNMP-EtherNet Adapter, Overview 1-12
 - Spanish 4-17
 - spare batteries on-site
 - important considerations 5-3
 - specifications
 - battery runtime C-5
 - environmental C-6
 - input C-2
 - output C-3
 - overview C-1
 - physical C-2
 - STANDBY button 3-2, 6-4
 - Standby mode 3-5
 - after installation 2-24
 - Status (LCD Menu) 4-6
 - Stop Bits 4-20
 - storage *See* batteries, care and storage
 - Sub-Menu Choices (LCD Menu) 4-5
 - symbols in text vii
 - symbols on equipment viii
 - system administrator
 - specifying the shutdown sequence 1-7
 - using Compaq Power Management Software 1-7
 - System Setup 4-16
- T**
- technical support ix
 - telephone numbers x
 - terminal block input cover
 - illustrated 2-10
 - terminal connection screws 2-11
 - terminal input block cover 2-10
 - Test/Reset Alarm button

- initiating a self-test 3-7
- warning on testing new batteries 5-9
- TEST/RESET ALARM button 3-2
- testing new batteries 5-9
- text conventions vii
- Trained Service Technicians 2-1
- Trouble Indicators 6-8
- Troubleshooting 6-1

U

- Unpacking the UPS 2-4
- UPS communication ports 2-18
- UPS components
 - reading firmware version (LCD Menu) 4-13
- UPS on Battery (LCD Menu) 4-12
- UPS Status + Load Segment status (LCD Menu) 4-6
- UPS Status+Active Alarm Count (LCD Menu) 4-6
- UPS-Computer Interface Cable
 - connecting from the UPS to the host computer 2-18
- user-serviceable components
 - none in R6000 2-1
- Utility Not Present (LCD Menu) 4-11
- utility voltage
 - "Utility Not Present" alarm 4-11
 - effects of varying outside nominal range 4-2
 - matching with UPS configuration 4-2
- utility voltage range *See* voltage range

V

- voltage level
 - updating 4-2
- voltage range
 - configuring to match the utility voltage 4-2
 - options tabulated 4-2

- updating 4-2
- updating the configuration 4-2

W

- warning
 - handling or connecting batteries 5-2
- Warning Audible Alarm 6-5
- warnings
 - component weight 5-7
 - electrical shock viii
 - equipment damage 5-7
 - heavy equipment handling 5-7
 - manual material handling 5-7
 - personal injury 5-7
 - rack stability ix
- Warnings
 - Batteries retain high voltage 5-7
 - battery circuit breaker off 2-12
 - battery handling
 - electrical 5-2
 - handling batteries 5-2
 - high leakage current 2-9
 - installation
 - positioning requirements 2-5
 - safety in Wiring 2-7
 - installation
 - adequate assistance to lift and stabilize 2-2
 - fixed rail requirement 2-5
 - lifting and stabilizing 2-5
 - manual material handling 2-2
 - occupational health and safety requirements 2-2
 - reduce weight 2-2
 - reducing weight 2-5
 - Installation
 - trained service technician 2-1
 - installation of ERMs
 - Trained Service Technician 2-17
 - Installation wiring
 - licensed electrician 2-1
 - lift-out tray usage 2-4
 - Lockout/Tagout 2-7, 2-9

- manual material handling 2-5
- occupational health and safety requirements 2-5
- Remote Emergency Power Off requirement 2-7
- Risk of Fire Notice 2-9
- warranty
 - \$25,000 Computer Load Protection Guarantee 1-14
 - accidental damage 1-14
 - applicability 1-14
 - limited warranty 1-14
 - qualifying 1-14
 - requirements 1-14
 - three-year limited 1-14
- website, Compaq x
- weight of R6000 2-2
- wiring
 - attachment to input terminal block 2-11
 - dedicated branch circuit 2-9
 - diagram location 2-10
 - High Leakage Current 2-9
 - Lockout/Tagout requirement 2-7

- REPO cable requirements 2-8
- Risk of Fire Notice 2-9
- terminal connection screw torque specifications 2-11
- wiring diagram 2-10
- wiring inspection panels 2-10
- wiring regulations and REPO capabilities 2-7
- wiring REPO port 2-8
- www.compaq.com 2-21
- www.compaq.com. ix

Y

- yellow LED 6-9
 - "UPS on Battery" alarm 4-12
 - Battery 4-11
 - Battery in Battery Mode 3-6
 - blinking 3-5
 - Bypass on in Bypass mode 3-5
- yellow LED On 6-9
- yellow LEDs 3-4